



ID3000 Series Smart Code Reader

User Manual

Legal Information

© 2020 Hangzhou Hikrobot Technology Co., Ltd. All rights reserved.

About this Manual

The Manual includes instructions for using and managing the Product. Pictures, charts, images and all other information hereinafter are for description and explanation only. The information contained in the Manual is subject to change, without notice, due to firmware updates or other reasons. Please find the latest version of this Manual at the Hikrobot website (<https://www.hikrobotics.com/>).

Please use this Manual with the guidance and assistance of professionals trained in supporting the Product.

Trademarks

HIKROBOT and other Hikrobot's trademarks and logos are the properties of Hikrobot in various jurisdictions. Other trademarks and logos mentioned are the properties of their respective owners.

Disclaimer

TO THE MAXIMUM EXTENT PERMITTED BY APPLICABLE LAW, THIS MANUAL AND THE PRODUCT DESCRIBED, WITH ITS HARDWARE, SOFTWARE AND FIRMWARE, ARE PROVIDED "AS IS" AND "WITH ALL FAULTS AND ERRORS". HIKROBOT MAKES NO WARRANTIES, EXPRESS OR IMPLIED, INCLUDING WITHOUT LIMITATION, MERCHANTABILITY, SATISFACTORY QUALITY, OR FITNESS FOR A PARTICULAR PURPOSE. THE USE OF THE PRODUCT BY YOU IS AT YOUR OWN RISK. IN NO EVENT WILL HIKROBOT BE LIABLE TO YOU FOR ANY SPECIAL, CONSEQUENTIAL, INCIDENTAL, OR INDIRECT DAMAGES, INCLUDING, AMONG OTHERS, DAMAGES FOR LOSS OF BUSINESS PROFITS, BUSINESS INTERRUPTION, OR LOSS OF DATA, CORRUPTION OF SYSTEMS, OR LOSS OF DOCUMENTATION, WHETHER BASED ON BREACH OF CONTRACT, TORT (INCLUDING NEGLIGENCE), PRODUCT LIABILITY, OR OTHERWISE, IN CONNECTION WITH THE USE OF THE PRODUCT, EVEN IF HIKROBOT HAS BEEN ADVISED OF THE POSSIBILITY OF SUCH DAMAGES OR LOSS.

YOU ACKNOWLEDGE THAT THE NATURE OF INTERNET PROVIDES FOR INHERENT SECURITY RISKS, AND HIKROBOT SHALL NOT TAKE ANY RESPONSIBILITIES FOR ABNORMAL OPERATION, PRIVACY LEAKAGE OR OTHER DAMAGES RESULTING FROM CYBER-ATTACK, HACKER ATTACK, VIRUS INFECTION, OR OTHER INTERNET SECURITY RISKS; HOWEVER, HIKROBOT WILL PROVIDE TIMELY TECHNICAL SUPPORT IF REQUIRED.

YOU AGREE TO USE THIS PRODUCT IN COMPLIANCE WITH ALL APPLICABLE LAWS, AND YOU ARE SOLELY RESPONSIBLE FOR ENSURING THAT YOUR USE CONFORMS TO THE APPLICABLE LAW. ESPECIALLY, YOU ARE RESPONSIBLE, FOR USING THIS PRODUCT IN A MANNER THAT DOES NOT INFRINGE ON THE RIGHTS OF THIRD PARTIES, INCLUDING WITHOUT LIMITATION, RIGHTS OF PUBLICITY, INTELLECTUAL PROPERTY RIGHTS, OR DATA PROTECTION AND OTHER PRIVACY RIGHTS. YOU SHALL NOT USE THIS PRODUCT FOR ANY PROHIBITED END-USES, INCLUDING THE DEVELOPMENT OR PRODUCTION OF WEAPONS OF MASS DESTRUCTION, THE DEVELOPMENT OR PRODUCTION OF CHEMICAL OR BIOLOGICAL WEAPONS, ANY ACTIVITIES IN THE CONTEXT RELATED TO ANY NUCLEAR EXPLOSIVE OR UNSAFE NUCLEAR FUEL-CYCLE, OR IN SUPPORT OF HUMAN RIGHTS

ABUSES.

THE PERFORMANCE DATA IN THIS PUBLICATION IS BASED ON HIKROBOT'S INTERNAL RESEARCH/EVALUATION. ACTUAL DATA MAY VARY DEPENDING ON SPECIFIC CONFIGURATIONS AND OPERATING CONDITIONS AND HIKROBOT SHALL NOT BEAR THE CONSEQUENCES ARISING THEREFROM.

IN THE EVENT OF ANY CONFLICTS BETWEEN THIS MANUAL AND THE APPLICABLE LAW, THE LATER PREVAILS.

Regulatory Information

FCC Information

Please take attention that changes or modification not expressly approved by the party responsible for compliance could void the user's authority to operate the equipment.

FCC compliance: This equipment has been tested and found to comply with the limits for a Class A digital device, pursuant to part 15 of the FCC Rules. These limits are designed to provide reasonable protection against harmful interference in a residential installation. This equipment generates, uses and can radiate radio frequency energy and, if not installed and used in accordance with the instructions, may cause harmful interference to radio communications. However, there is no guarantee that interference will not occur in a particular installation. If this equipment does cause harmful interference to radio or television reception, which can be determined by turning the equipment off and on, the user is encouraged to try to correct the interference by one or more of the following measures:

- Reorient or relocate the receiving antenna.
- Increase the separation between the equipment and receiver.
- Connect the equipment into an outlet on a circuit different from that to which the receiver is connected.
- Consult the dealer or an experienced radio/TV technician for help.

FCC Conditions

This device complies with part 15 of the FCC Rules. Operation is subject to the following two conditions:

- This device may not cause harmful interference.
- This device must accept any interference received, including interference that may cause undesired operation.

EU Conformity Statement



This product and - if applicable - the supplied accessories too are marked with "CE" and comply therefore with the applicable harmonized European standards listed under the EMC Directive 2014/30/EU, LVD Directive 2014/35/EU, the RoHS Directive 2011/65/EU.



2012/19/EU (WEEE directive): Products marked with this symbol cannot be disposed of as unsorted municipal waste in the European Union. For proper recycling, return this product to your local supplier upon the purchase of equivalent new equipment, or dispose of it at designated



collection points. For more information see: <http://www.recyclethis.info>.



2006/66/EC (battery directive): This product contains a battery that cannot be disposed of as unsorted municipal waste in the European Union. See the product documentation for specific battery information. The battery is marked with this symbol, which may include lettering to indicate cadmium (Cd), lead (Pb), or mercury (Hg). For proper recycling, return the battery to your supplier or to a designated collection point. For more information see: <http://www.recyclethis.info>.

Symbol Conventions

The symbols that may be found in this document are defined as follows.

Symbol	Description
 Danger	Indicates a hazardous situation which, if not avoided, will or could result in death or serious injury.
 Caution	Indicates a potentially hazardous situation which, if not avoided, could result in equipment damage, data loss, performance degradation, or unexpected results.
 Note	Provides additional information to emphasize or supplement important points of the main text.

Available Model

This manual is applicable to the ID3000 Series Smart Code Reader.

Safety Instruction

These instructions are intended to ensure that the user can use the product correctly to avoid danger or property loss.

Laws and Regulations

The device should be used in compliance with local laws, electrical safety regulations, and fire prevention regulations.

Power Supply

- When wiring or dismantling, make sure that the device power is cut off, and do not operate under electrification.
- Avoid contact with exposed circuit. When the device is powered on, avoid contact with exposed junctions and parts.
- DO NOT connect multiple devices to one power adapter, to avoid over-heating or fire hazards caused by overload.
- Make sure the plug is properly connected to the power socket.

Transportation

- The product contains precision optical components and electronic components. During transportation, storage and installation, incorrect operations like heavy pressure and violent vibration should be avoided. Otherwise, the product may be damaged.
- Avoid sudden collision, and pack the product with the accompanied carton and cushioning material or similar package.

Using Environment

- Do not touch the heat-radiating part of the device to avoid scalding.
- In order to reduce the risk of fire or electric shock, do not let the product get wet or damp.
- Do not drop objects onto the product and avoid vigorous vibration.
- Keep the product away from magnetic interference.
- Do not use the product in extremely heat, extremely cold, dusty environment, corrosive environment or high humidity environment.
- Do not aim the product lens at objects of strong light, such as the sun and incandescent lamp. Otherwise, the lens may be damaged.
- The product should be stored in dry environment without corrosive gas. Avoid placing the product in direct sunlight and poorly ventilated locations, or near heat sources such as heater or heating (ignoring this warning may lead to fire hazards).
- Do not operate in explosive environment.
- Keep the surrounding area well ventilated to avoid heat accumulation. Do not contact the radiator directly to avoid scald.

Electrostatic Protection

- Remove all conductive objects (such as jewelry, watch, etc.) on the product body before touching the product, and touch the grounding metal bracket by hand to release the static electricity.
- It is suggested to wear anti-static suit to prevent damage to the equipment caused by static electricity.
- When installing or maintaining the product, please wear anti-static wrist band or anti-static gloves. Make sure that the wristband is tightly attached to the skin and is reliably grounded.
- It is forbidden to touch exposed circuit boards with bare hands. Static electricity generated by human body may damage electrostatic sensitive components on circuit boards.
- When touching electrostatic sensitive components or devices, proper grounding measures must be taken.
- Put electrostatic sensitive components into anti-static bags for protection.
- It is suggested to place humidifier in dry environment to maintain suitable humidity and reduce static electricity generation.

Maintenance

- If the product is not working properly, contact the store or the nearest service center. Do not disassemble or modify the device in any way. (The company does not bear any liability for any problem arising from unauthorized modification or maintenance).
- Please properly preserve all the original packaging materials of the product so that when

problems arise, the product can be packed with packaging materials and sent to the agent or returned to the manufacturer for processing. The company does not bear any liability for accidental damage during transportation caused by non-original packaging.

- This product is a precision electronic device, no components can be maintained by user, please do not disassemble the device arbitrarily.

Cleaning

Please do not touch the image sensor directly. If the sensor needs to be cleaned, please use a clean rag and wet it with alcohol, then gently wipe off the dirt; if the camera is not in use, please cover the image sensor with dust cover for protection.

Installation

Please do not install the product on vibrating surface or places that are vulnerable to impact.

Personnel Requirement

Quality requirements for installation and maintenance personnel: qualification certificate or working experience in weak current system installation and maintenance, and relevant working experience and qualifications. Besides, the personnel must possess the following knowledge and operation skills:

- The basic knowledge and operation skills of low voltage wiring and Low voltage electronic circuit connection.
- The ability to comprehend the contents of this manual.

Contact Information

Hangzhou Hikrobot Technology Co., Ltd.

No. 399 Danfeng Road, Binjiang District, Hangzhou, 310051, China

E-mail: tech_support@hikrobotics.com

Website: <https://en.hikrobotics.com/>

Contents

Chapter 1 Appearance	1
Chapter 2 Interface Description	3
Chapter 3 I/O Wiring	5
3.1 Input Signal	5
3.2 Output Signal	6
3.3 Input Signal Wiring	7
3.4 Output Signal Wiring	9
3.5 RS-232 Serial Port	10
Chapter 4 Installation	12
4.1 Installation Preparation	12
4.2 Install Device	12
4.3 Install Client Software	13
4.4 Turn off Firewall	13
Chapter 5 Network Settings	15
5.1 Set PC Network.....	15
5.2 Set Camera Network	16
5.3 Connect Camera to Client Software	16
Chapter 6 Client Software Layout	17
Chapter 7 Camera Mode Settings	19
Chapter 8 Camera Settings	21
8.1 Image Quality Settings	21
8.1.1 Set Image	21
8.1.2 Set Light Source	25
8.1.3 Set Auto Focus	27
8.1.4 Set Mirror X	28
8.1.5 Set Test Pattern	28
8.2 Barcode Algorithm Settings	29
8.2.1 Add Barcode	29
8.2.2 Set 1D Algorithm Parameter	29

8.2.3 Set 2D Algorithm Parameter	30
8.2.4 Set Code Reading ROI	33
8.3 Signal Input Settings	34
8.3.1 Set Trigger Mode	34
8.3.2 Enable Internal Trigger Mode	34
8.3.3 Enable External Trigger Mode	35
8.3.4 Stop Trigger	38
8.4 Signal Output Settings	42
8.4.1 Select Output Signal	42
8.4.2 Enable Line Inverter	42
8.4.3 Set Event Source	43
8.5 Code Reading Result Settings	51
8.5.1 Set Code Reading Result Output Mode	51
8.5.2 Set Filter Rule	51
8.5.3 Set Result Format	53
8.6 Communication Settings	64
8.6.1 Smart SDK	64
8.6.2 TCP Client	64
8.6.3 TCP Server	65
8.6.4 Serial	65
8.6.5 FTP	66
8.6.6 HTTP	67
8.6.7 Profinet	67
8.6.8 Melsec	67
8.6.9 Ethernet/IP	69
8.6.10 ModBus	69
8.7 User Set Customization	70
Chapter 9 Camera Operation	72
9.1 Live View	72
9.2 Enable Acquisition	72
9.3 Add Cross Line	73

9.4 Start Recording	73
9.5 Split Window	74
9.6 View Reports	74
9.7 View Log.....	75
9.8 Enable Camera Auto Work.....	75
Chapter 10 Camera Maintenance	76
10.1 Update Firmware.....	76
10.2 Reboot Device	76
Chapter 11 FAQ (Frequently Asked Question)	78
11.1 Why the image is very dark?.....	78
11.2 Why the image's frame rate is very low in the live view?	78
11.3 Why there is no camera listed after I run the IDMVS client software?	78
11.4 Why there is no image in the live view?	79

Chapter 1 Appearance

Note

Appearance here is for reference only. Refer to the device's specification for detailed dimension information.

Currently, ID3000 series smart code reader has 2 types, including manual focus device and mechanical focus device.

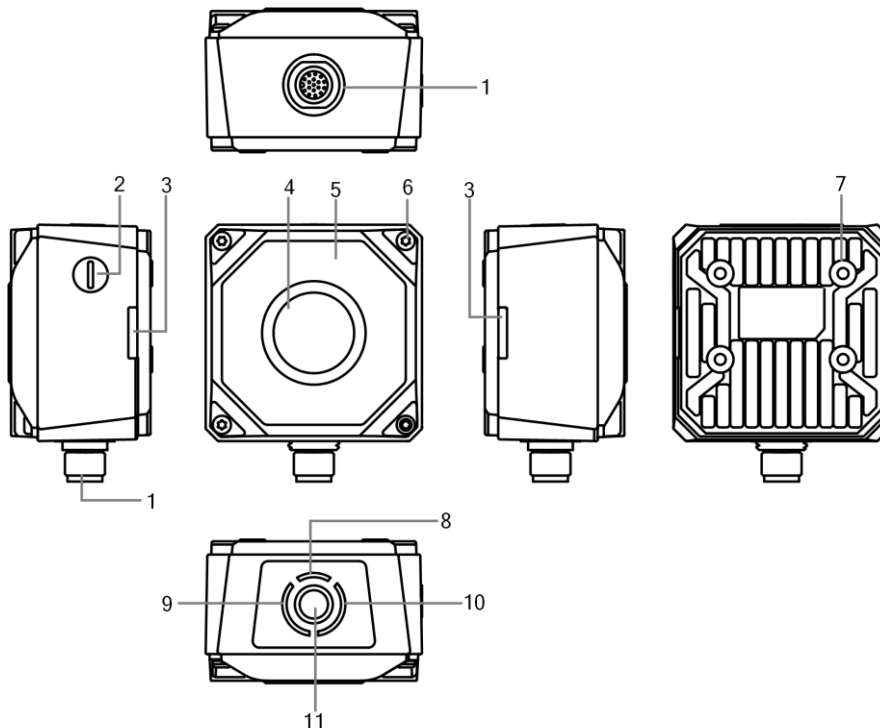

Figure 1-1 Appearance

Table 1-1 Appearance Description

No.	Name	Description
1	17-Pin Interface	It provides power, input/output, Ethernet, and serial port signal. The interface is designed with screw threads to tighten connection between the device and cable, and thus avoiding influence caused by vibration.
2	Focus Knob	It is used to adjust focal length manually. Note The mechanical focus device does not have the focus knob.

ID3000 Series Smart Code Reader User Manual

No.	Name	Description
3	OK/NG Indicator	It indicates code reading result. <ul style="list-style-type: none">● The indicator is orange when the device is starting up.● The indicator is red after the device is powered on.● The indicator is flashing green after the device reads barcodes, and it is solid green if the device reads barcodes continuously.
4	Lens Cap	It can be replaced with other lens cap. Polarization lens cap is optional.
5	Light Source	The device has 8 LED lamps providing light, and you can select wide-angle or spotlight lamps. White, red or blue lamp is recommended.
6	Screw	It refers to the screw between device body and lens cap.
7	Screw Hole	It is used to fix the device to installation position. You should use M4 screw.
8	PWR Indicator	It is the power indicator. The indicator is green when the device operates normally. Otherwise, it is red.
9	STS Indicator	It is the device status indicator. The indicator is green when the device operates normally. When the device starts up or exception occurs, it is red.
10	LNK Indicator	It is network status indicator. The indicator is flashing green when the network transmission is normal. Otherwise, it is unlit.
11	Button	When the device is in continuous acquisition mode, press the button and the device enters trigger mode. When the device is in trigger mode, press the button and the device triggers once.

Chapter 2 Interface Description

Read the following section to get definitions of 17-pin interface.

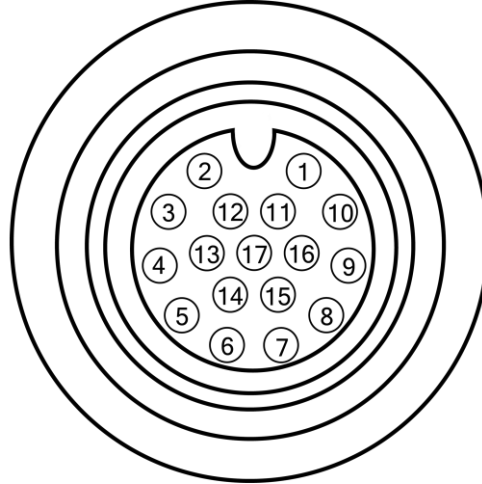

Figure 2-1 17-Pin Interface

Table 2-1 Pin Definitions

No.	Signal	I/O Signal Source	Description
1	POWER_IN	--	Direct current power supply positive
2	DO_2	LineOut2 signal line	Output
3	Reserved		
4	RS232TX	--	RS-232 serial port output
5	RS232RX	--	RS-232 serial port input
6	MDI0+	--	Fast Ethernet signal MDI0+
7	MDI1-	--	Fast Ethernet signal MDI1-
8	DO_0	LineOut0 signal line	Output
9	DI_2	LineIn2 signal line	Input
10	DO_1	LineOut1 signal line	Output
11	GND	Signal ground	Direct current power supply negative
12	Reserved		
13	Reserved		
14	MDI0-	--	Fast Ethernet signal MDI0-
15	MDI1+	--	Fast Ethernet signal MDI1+

No.	Signal	I/O Signal Source	Description
16	DI_0	LineIn0 signal line	Input
17	DI_1	LineIn1 signal line	Input

Note

- You should refer to the table above and the label attached to the power and I/O cable to wire the device.
- It is recommended to use the supplied 17-pin cable. The 6th, 7th, 14th, and 15th pin have been made as RJ45 connector. The lines of other pins should be wired according to the actual demands.

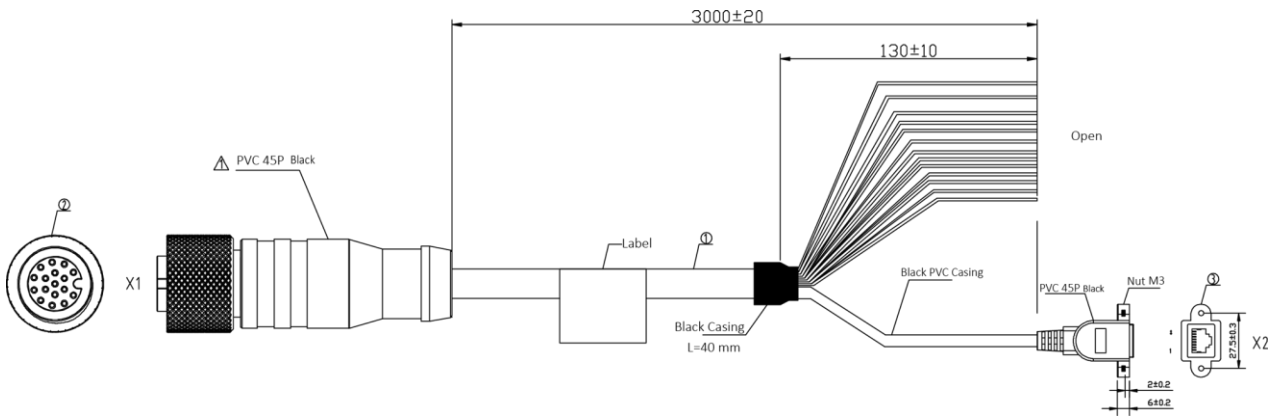

Figure 2-2 17-Pin Cable

Chapter 3 I/O Wiring

3.1 Input Signal

The device's LineIn 0/1/2 are input signals, and their internal circuit is as follows.

Note

- The maximum input current of input signal is 25 mA.
- The breakdown voltage is 36 VDC. Keep voltage stable.

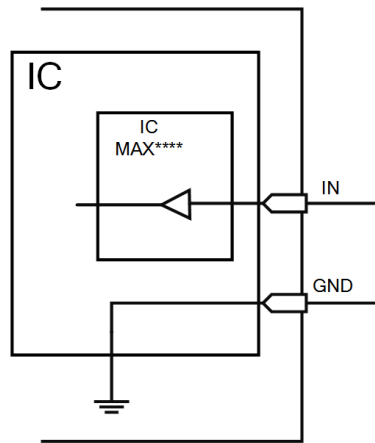

Figure 3-1 Internal Circuit of Input Signal

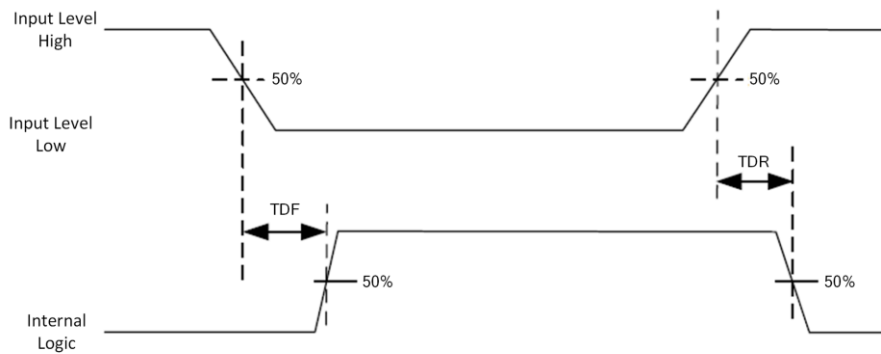

Figure 3-2 Input Logic Level

Table 3-1 Input Electrical Feature

Parameter Name	Parameter Symbol	Value
Input Logic Level Low	VL	0 VDC to 9 VDC (VCC=24 VDC) 0 VDC to 5.4 VDC (VCC=12 VDC)
Input Logic Level High	VH	11 VDC to 24 VDC (VCC=24 VDC) 7.56 VDC to 12 VDC (VCC=12 VDC)
Input Falling Delay	TDF	1.3 μ s to 3.5 μ s
Input Rising Delay	TDR	1.3 μ s to 3.5 μ s

Note

VCC stands for Volt Current Condenser, and it is the device's input voltage.

3.2 Output Signal

The device's LineOut 0/1/2 are output signals, and their internal circuit is as follows.

Note

The maximum output current of output signal is 200 mA.

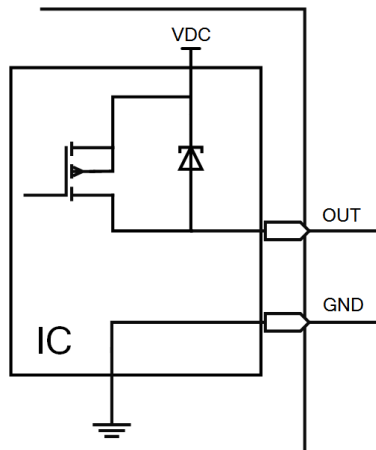

Figure 3-3 Internal Circuit of Output Signal

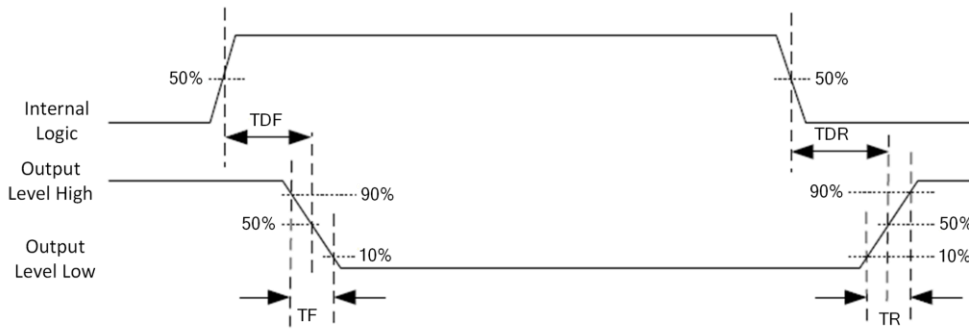

Figure 3-4 Output Logic Level

When the external voltage and resistance is 12 VDC and 1 K Ω respectively, output electrical feature is as follows.

Note

If the external voltage and resistance change, the corresponding current of output signal and output logic level low may differ.

Table 3-2 Output Electrical Feature

Parameter Name	Parameter Symbol	Value
Output Logic Level Low	VL	212 mV
Output Logic Level High	VH	11.8 VDC
Output Falling Delay	TDF	0.4 μ s
Output Rising Delay	TDR	0.4 μ s
Output Falling Time	TF	0.4 μ s
Output Rising Time	TR	0.4 μ s

3.3 Input Signal Wiring

The device can receive the external input signal via I/O interface, and here we take LineIn 0 as an example to introduce input signal wiring.

Note

Input signal wiring may differ by external device types.

PNP Device

Note

It is recommended to use 330 Ω pull-down resistor.

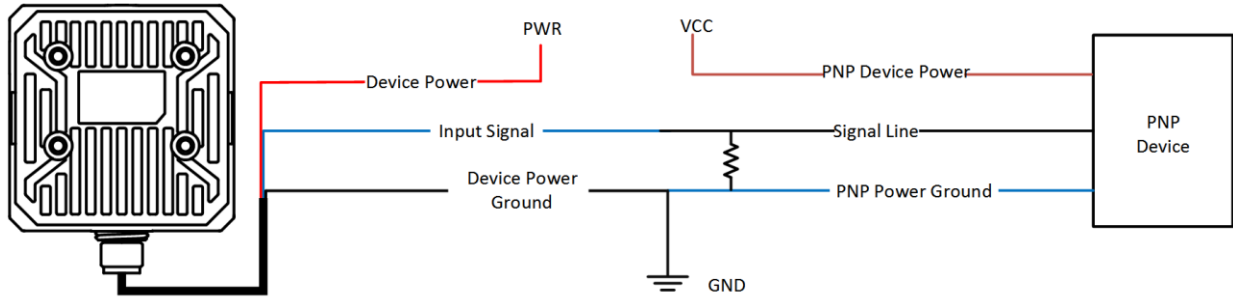

Figure 3-5 Input Signal Connecting to PNP Device

NPN Device

Note

If the VCC of NPN device is 12 VDC or 24 VDC, and it is recommended to use 1 K Ω pull-up resistor.

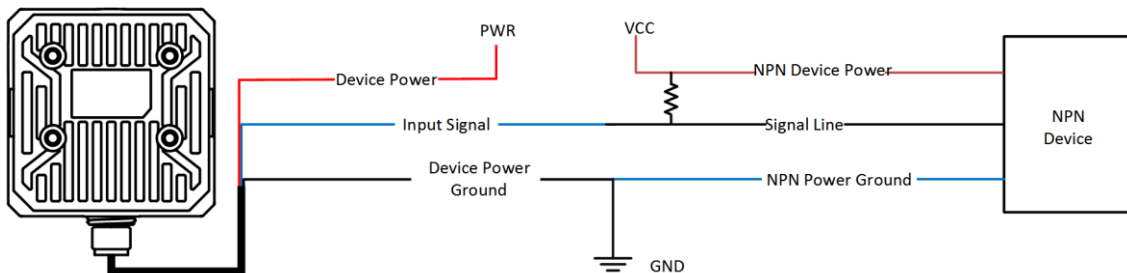

Figure 3-6 Input Signal Connecting to NPN Device

Switch

Note

It is recommended to use 330 Ω pull-down resistor.

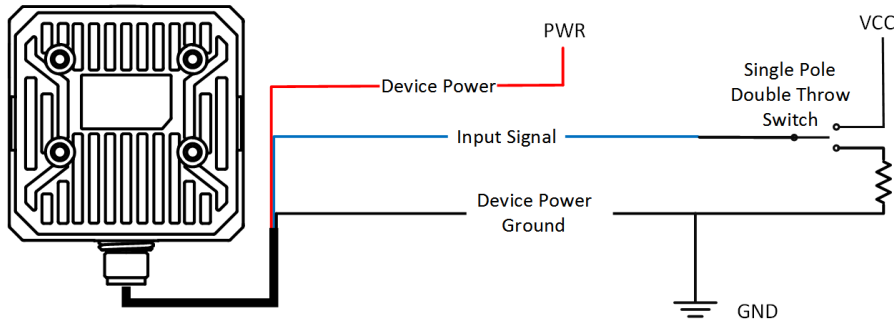

Figure 3-7 Input Signal Connecting to a Switch

3.4 Output Signal Wiring

The device can output signal to external devices via I/O interface, and here we take LineOut 0 as an example to introduce output signal wiring.

Note

- Output signal wiring may differ by external device types.
- The voltage of VCC should not higher than that of PWR. Otherwise, the device's output signal may have exception.

PNP Device

Note

It is recommended to use 330 Ω pull-down resistor.

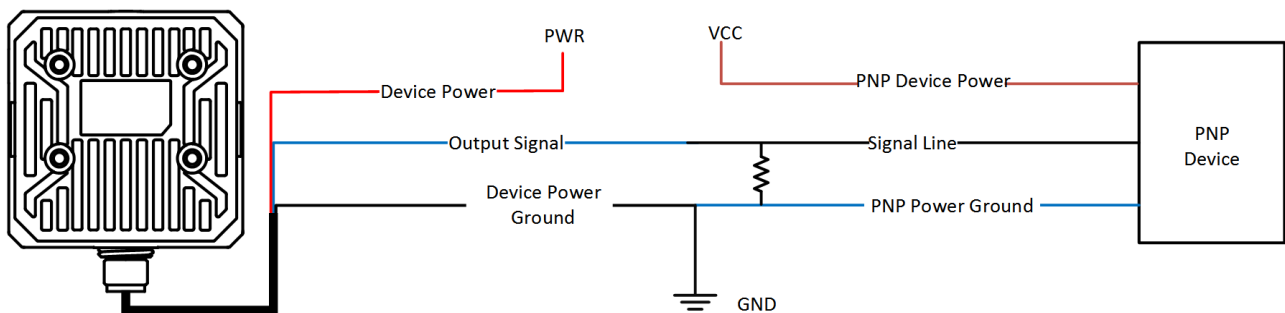

Figure 3-8 Output Signal Connecting to PNP Device

NPN Device

Note

If the VCC of NPN device is 12 VDC or 24 VDC, and it is recommended to use 1 K Ω pull-up resistor.

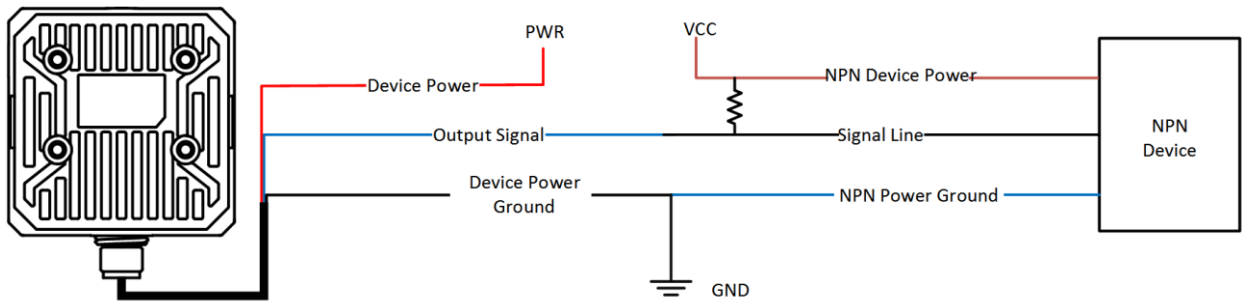

Figure 3-9 Output Signal Connecting to NPN Device

3.5 RS-232 Serial Port

The 9-pin male connector and 25-pin male connector are commonly used serial ports, as shown below. You can refer to the table below for the specific pin name and function.

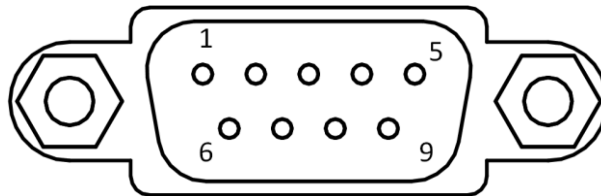

Figure 3-10 9-Pin Interface

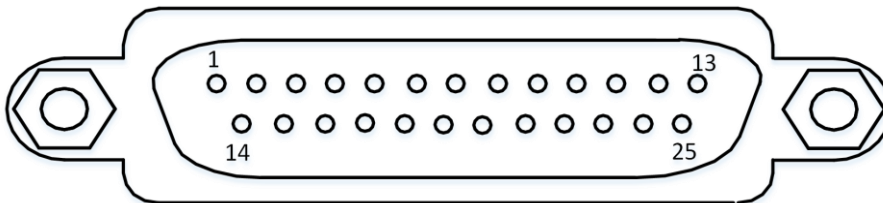

Figure 3-11 25-Pin Interface

Table 3-3 Description

Serial Port Type	Pin No.	Name	Function
9-Pin Interface	2	RX	Receive data
	3	TX	Send data
	5	GND	Signal ground
25-Pin Interface	2	TX	Send data
	3	RX	Receive data
	7	GND	Signal ground

You can refer to the serial port wiring below to connect the device with an external device.

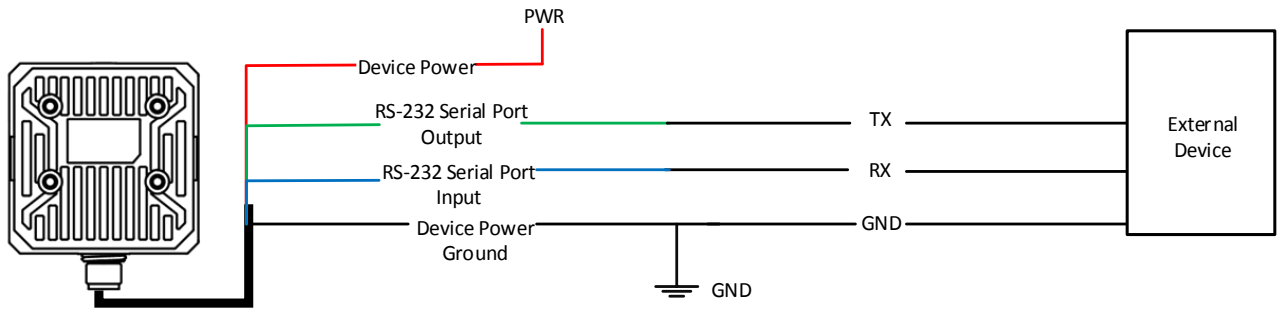

Figure 3-12 RS-232 Serial Port Wiring

Chapter 4 Installation

4.1 Installation Preparation

You need to prepare following accessories before installation.

Table 4-1 Accessories

No.	Name	Quantity	Description
1	17-Pin Cable	1	It refers to the supplied 17-pin cable that is included in the package.
2	Power Adapter or Switch Power Supply	1	You should select suitable power adapter or switch power supply according to the device power supply and consumption. You need to purchase separately.
3	Lens Cap	1	It refers to the supplied lens cap. You can also use polarization lens cap that needs to be purchased separately.
4	Light Source	1	It refers to the supplied white light source. You can also use red or blue light source that needs to be purchased separately.
5	M4 Screw	4	It refers to the supplied M4 screw that is used to fix the device to installation position.

4.2 Install Device

Before You Start

- Make sure the device in the package is in good condition and all the assembly parts are included.
- Make sure all the related equipment is power-off during the installation.

Steps

1. Use M4 screw to fix the device to the installation position.
2. Connect the device to a power adapter or switch power supply via 17-pin cable.
3. Connect the device to a switch via network cable.

4.3 Install Client Software

IDMVS is a client software for camera configuration and remote operations.

Steps

Note

- Check the Windows version. The client software is compatible with 32/64-bit Windows XP/7/10.
 - You can get the client software installation package from <https://en.hikrobotics.com/>.
 - The graphic user interface may differ by different versions of client software you use. Here we take version 2.2.0 as an example.
-

1. Double click the installation package to start installing the client software.
2. Select the language.
3. Read and check **Terms of the License Agreement**.
4. Click **Start Setup**.
5. Select installation directory and click **Next**.

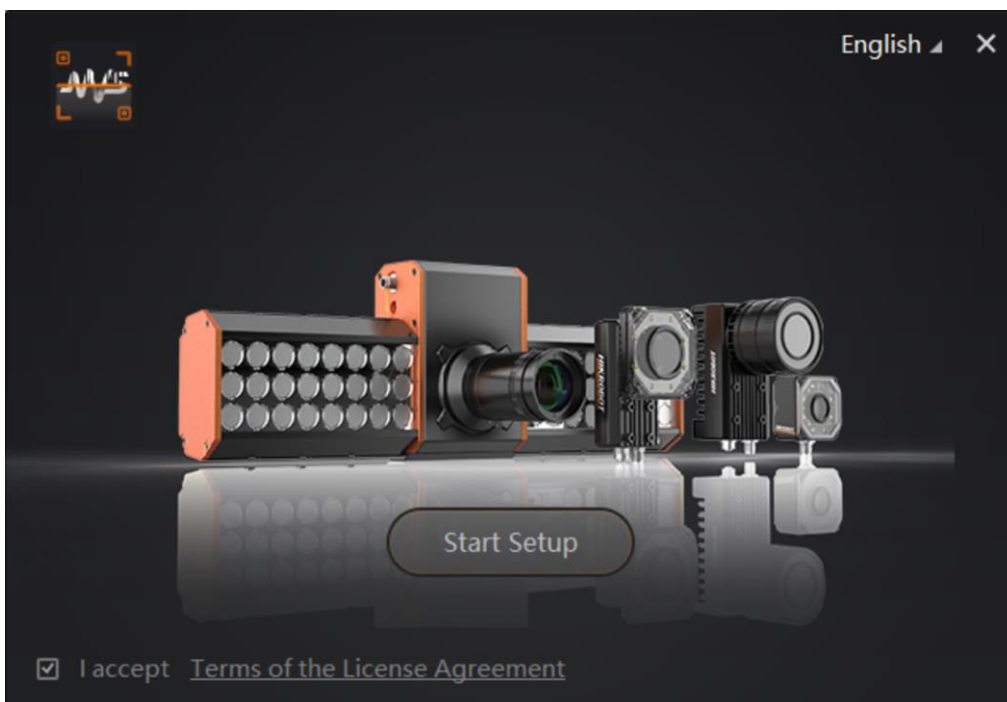

Figure 4-1 Installation Interface

6. Finish the installation according to the interface prompts.

4.4 Turn off Firewall

To ensure stable client running and image transmission, you are recommended turning off

Windows firewall before using the client software.

Steps

Note

For different Windows versions, the path name or interface may differ. Please refer to the actual condition.

1. Go to Windows Firewall.

Windows XP system: Click **Start** → **Control Panel** → **Security Center** → **Windows Firewall**.

Windows 7 system: Click **Start** → **Control Panel** → **Windows Firewall**.

Windows 10 system: Click **Start** → **Control Panel** → **System and Security** → **Windows Defender Firewall**.

2. Click **Turn Windows Defender Firewall on or off** on the left.

3. Select **Turn off Windows Defender Firewall (not recommended)**.

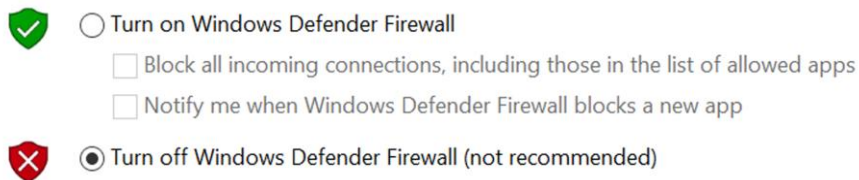

Figure 4-2 Windows Defender Firewall

4. Click **OK**.

Chapter 5 Network Settings

5.1 Set PC Network

To ensure stable image transmission and normal communication between the PC and the camera via client software, you need to set the PC network before using the client software.

Steps

Note

For different Windows versions, the specific setting path and interface may differ. Please refer to the actual condition.

1. Go to PC network settings page: **Start** → **Control Panel** → **Network and Internet** → **Network and Sharing Center** → **Change adapter settings**.
2. Select NIC and set the IP obtainment mode.
Select **Obtain an IP address automatically** to get an IP address of the PC automatically.
Or select **Use the following IP address** to set an IP address for the PC manually.

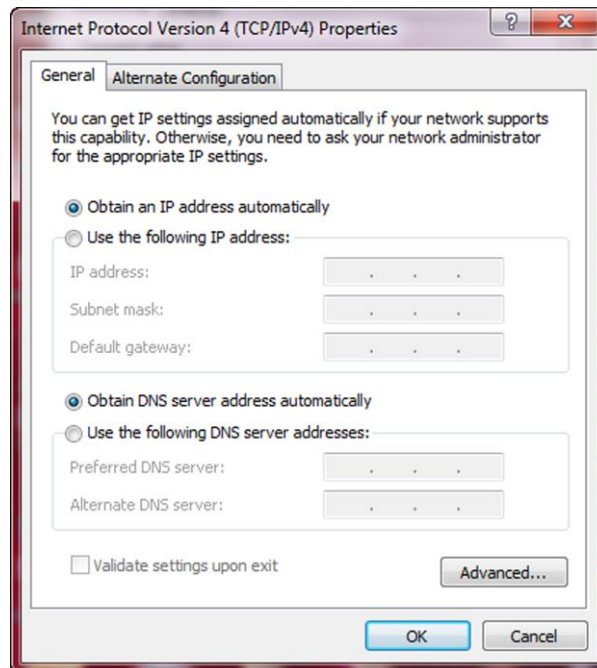



Figure 5-1 Set PC Network

5.2 Set Camera Network

You can set and operate the camera in the client software only when the camera is in the same network segment with the PC where the client software is installed.

Steps

1. Double click the client software to run it.
2. Click  to find the device.
3. Right click the device to be connected.
4. Click **Modify IP**.
5. Set the IP address of the device in the same network segment with the PC.

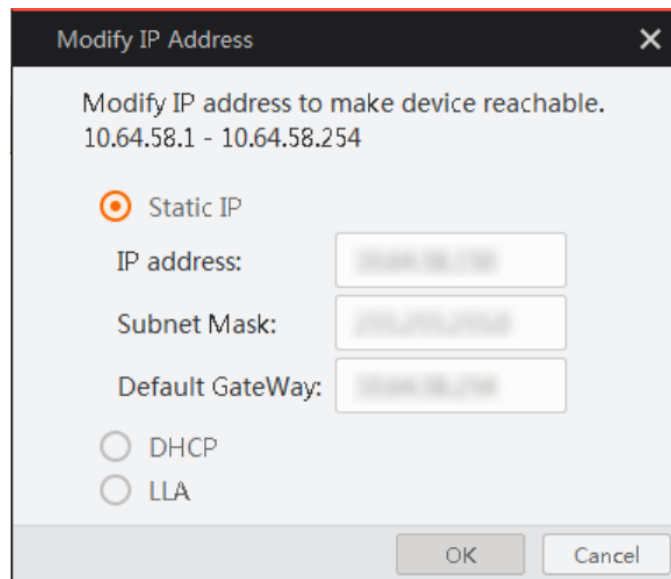



Figure 5-2 Modify IP Address

6. Click **OK**.

5.3 Connect Camera to Client Software

Make sure your camera IP address is in the same network segment with the PC where you installed the client software before connecting the camera to it.

Double click the camera name in the device list, or click  to connect the camera to the client.

Chapter 6 Client Software Layout

After connecting to the device, the client software can read the device information and display it.

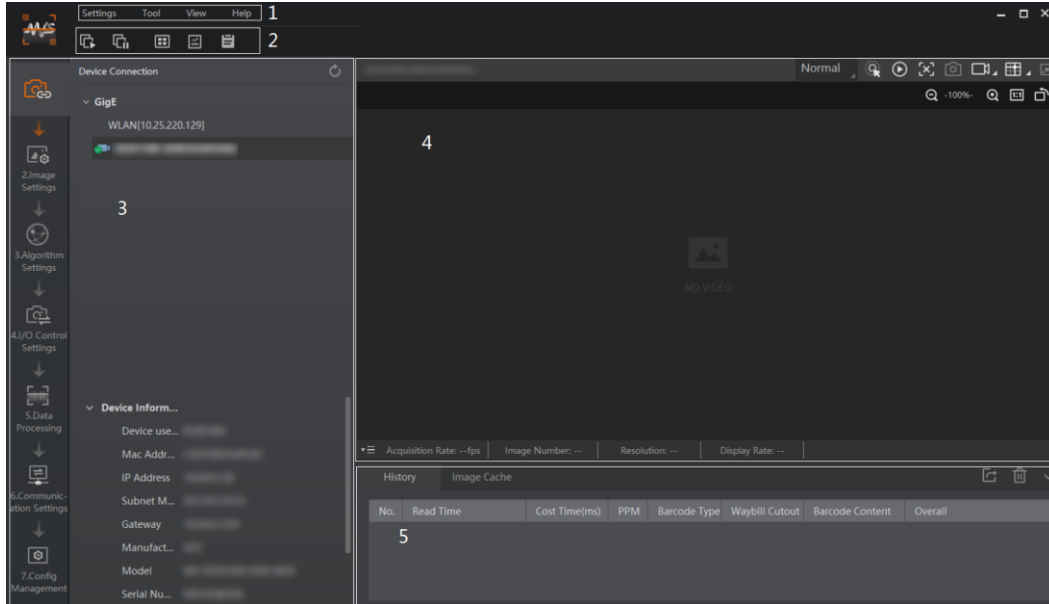

Figure 6-1 Main Window

Note

The specific interfaces of the client software may differ by its versions.

Table 6-1 Description of the Main Window

No.	Name	Description
1	Menu Bar	The menu bar displays function modules, including Settings , Tool , View , and Help .
2	Control Toolbar	The control toolbar provides quick operations for the device. You can click different icons to start or stop batch acquisition, change window layout, view statistics information, and device log.
3	Device Configuration Area	You can connect or disconnect device, set parameters, and modify device IP address in this area.
4	Live View Window	This area displays the acquisition images and algorithm reading result in real-time. You can click different icons to capture and save image, record, etc.
5	History Record and Image Cache	This area displays different barcode information read by the device in real-time, including read time, cost time, code type, content, code score, etc. You can also set image cache here.

You can set device parameters in device configuration area.

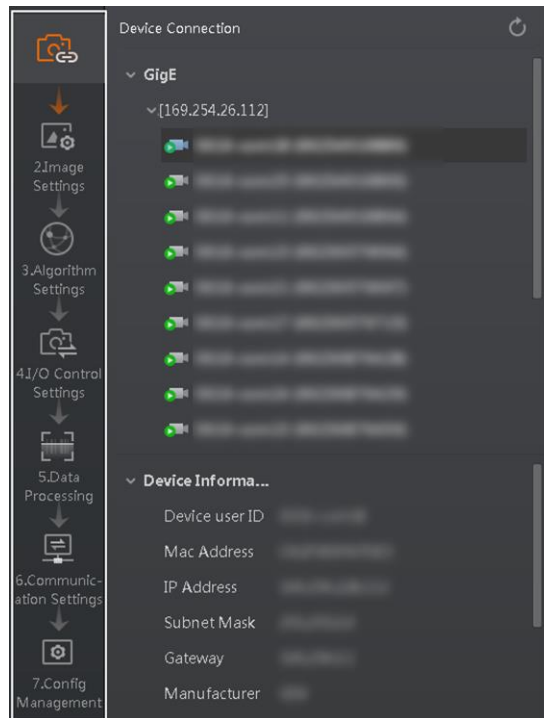

Figure 6-2 Device Configuration Area

Table 6-2 Description

No.	Module Name	Description
1	Device Connection	You can connect or disconnect device, modify device IP address, view device information, etc.
2	Image Settings	You can set image parameters, light parameters, etc.
3	Algorithm Settings	You can add different barcodes, set barcode number, etc.
4	I/O Control Settings	You can set parameters related with input and output.
5	Data Processing	You can set filter rule for output result.
6	Communication Settings	You can select different communication protocols, and set related parameters for output result.
7	Configuration Management	You can save and load user parameters, and restart the device.

Chapter 7 Camera Mode Settings

The device supports 3 types of operating modes, including **Test**, **Normal**, and **Raw**. You can select different modes in live view window according to actual demands.

Note

- Stopping the real-time acquisition is required before selecting modes.
- You need to set camera mode as **Normal** before specific camera settings. Otherwise, the camera parameters may be different.

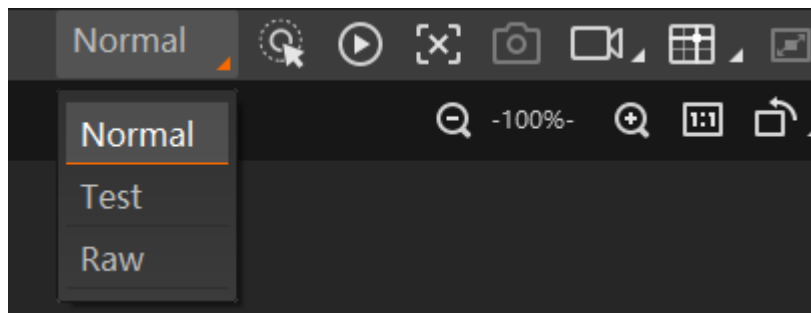



Figure 7-1 Select Camera Mode

Table 7-1 Description

Camera Mode	Description
Test Mode	It is used during camera debugging. The camera outputs images that are acquired in real-time, and displays code information.
Normal Mode	It is used during camera normal operation. After reading code in image, the camera outputs image and code information.
Raw Mode	It is used during testing image data. The camera outputs raw data and displays code information.

You can click  in the live view window to view images and the code reading effect. If the effect is not very good, you can adjust the focus knob (the manual focus device only) or related parameters in **Image Settings** area.

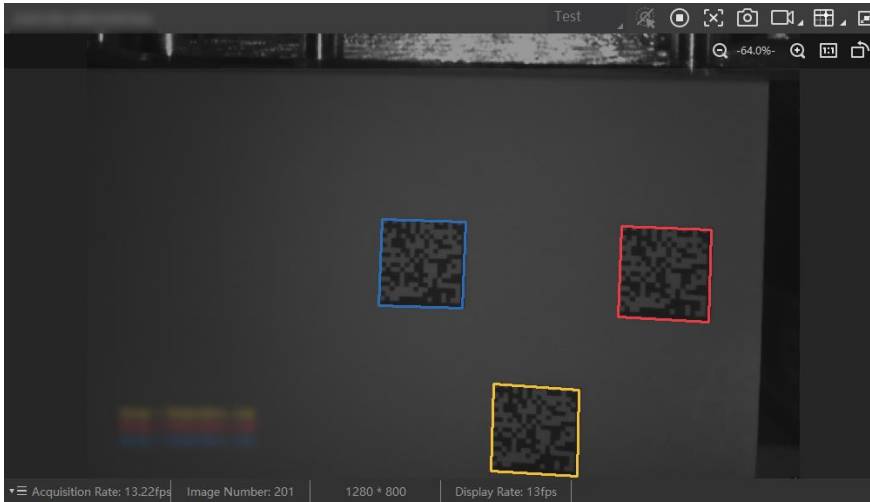

Figure 7-2 Code Reading

Chapter 8 Camera Settings

You are recommended to complete camera settings in following order: **Device Connection** → **Image Settings** → **Algorithm Settings** → **I/O Control Settings** → **Data Processing** → **Communication Settings** → **Configuration Management**.

Note

Before specific camera settings, you need to set camera mode as Normal. Otherwise, the camera parameters may be different. Regarding camera mode, refer to **Camera Mode Settings** for details.

- **Device Connection:** It tells you how to connect the camera to the client software. And you can configure and operate the camera remotely via the client software only when you have connected the camera to the client software. Refer to **Connect Camera to Client Software** for details.
- **Image Settings:** It tells you how to set image related parameters of the camera via client software. Refer to **Image Quality Settings** for details.
- **Algorithm Settings:** It tells you how to set the types of barcode to be read, the 1D code algorithm, the 2D code algorithm, etc. Refer to **Barcode Algorithm Settings** for details.
- **I/O Control Settings:** It tells you how to set the parameters related to the control of input and output signals of device. Refer to **Signal Input Settings** and **Signal Output Settings** for details.
- **Data Processing:** It tells you how to set filter rules for reading barcodes and other data processing related parameters. Refer to **Code Reading Result Settings** for details.
- **Communication Settings:** It tells you how to select different communication protocols, and set their corresponding parameters. Refer to **Communication Settings** for details.
- **Configuration Management:** It tells you how to set and manage the user parameters, restart device, etc. Refer to **User Set Customization** for details.

8.1 Image Quality Settings

This section introduces how to set image related parameters of the camera via client software.

Note

For different models of the camera, the specific parameters may differ, and the actual device you purchased shall prevail.

8.1.1 Set Image

For image quality settings, setting exposure time, gain, Gamma and other parameters is available. You can set these parameters based on fixed value, or use the polling function to let the device to acquire images based on single or multiple sets of parameters you configured.

Set Image Parameters

You can set different image parameters like exposure time, gain, Gamma, acquisition frame rate, acquisition burst frame count in image parameters interface.

Note

- Make sure you have select the camera to be set in Device Connection before setting image parameters.
 - For specific parameter range like exposure time, gain and acquisition frame rate, refer to the camera's specification for details.
-

Exposure Time

You can increase exposure time to improve image brightness.

Note

To some extent, increasing exposure time will reduce acquisition frame rate, and impact image quality.

Gain

You can increase gain to improve image brightness.

Note

To some extent, increasing gain will create more image noises, and impact image quality.

Gamma

Gamma allows you to adjust the image contrast. It is recommended to reduce Gamma to increase brightness in dark background.

Acquisition Frame Rate

Acquisition frame rate refers to the image number that is acquired by the camera per second.

Acquisition Burst Frame Count

Acquisition burst frame count refers to the outputted image number when the camera is triggered once.

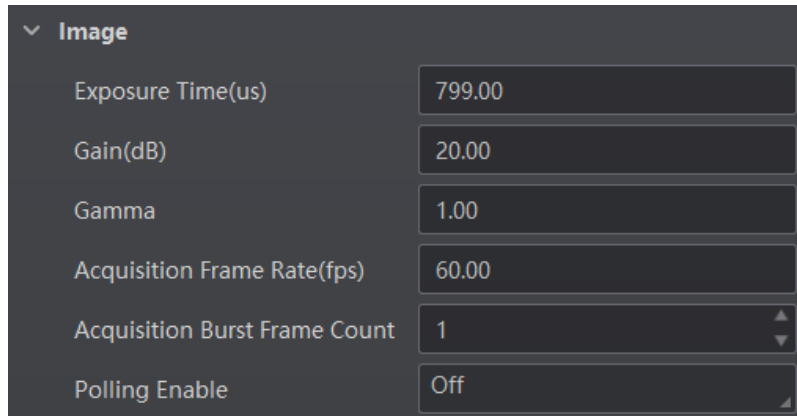

Figure 8-1 Set Image

Set Parameters for Polling Function

The polling function allows the device to acquire images based on the parameters you set, including exposure time, gain, Gamma, and light source. Currently, 2 types of polling modes are available, including single mode and multiple mode.

Single Mode

Note

- Stopping the real-time acquisition is required before setting the polling function.
- After the polling enabled, the device acquires images with its max. frame rate. Once the polling disabled, the frame rate you set in **Acquisition Frame Rate** takes effect.
- The polling function may differ by device models.

Go to **Image Settings** → **Image** → **Polling Enable**, and select **Single** as **Polling Enable**.

Select one parameter (e.g. **Param1**) from **Polling Param**, and set **Polling Exposure Time**, **Polling Gain**, and **Polling Gamma** according to actual demands

You can select **Polling Light Selector** according to actual demands, and enable **Polling Light Enable**.

Polling Enable	Single
Polling Param	Param1
Polling Exposure Time	799.00
Polling Gain	0.00
Polling Gamma	1.00
Polling Light Selector	Up
Polling Light Enable	<input checked="" type="checkbox"/>

Figure 8-2 Single Mode

Multiple Mode

Note

- The parameter of Best Polling Group Idx is used to display the polling parameter number when the device recognizes codes after enabling polling. If the polling is disabled or polling parameters are edited, it displays 1 by default.
- The rule for multiple-mode polling is that the polling is started from the polling parameter with Best Polling Group Idx, and then execute other polling parameters you selected in turn. For example, if the Param3 is the Best Polling Group Idx and Param1, Param2, Param4 and Param5 are enabled, the polling order is Param3 > Param1 > Param2 > Param4 > Param5.

Go to **Image Settings** → **Image** → **Polling Enable**, and select **Multiple** as **Polling Enable**.

Set **Polling Time** and **Polling Period** according to actual demands, select 2 to 8 sets of parameters (e.g. **Param1** and **Param2**) from **Polling Param**, and enable **Polling Param Enable** to let them take effect.

Set **Polling Exposure Time**, **Polling Gain**, and **Polling Gamma** for the **Polling Param** you selected, select **Polling Light Selector** according to actual demands, and enable **Polling Light Enable**.

Repeat steps above to set other parameters from **Polling Param**.

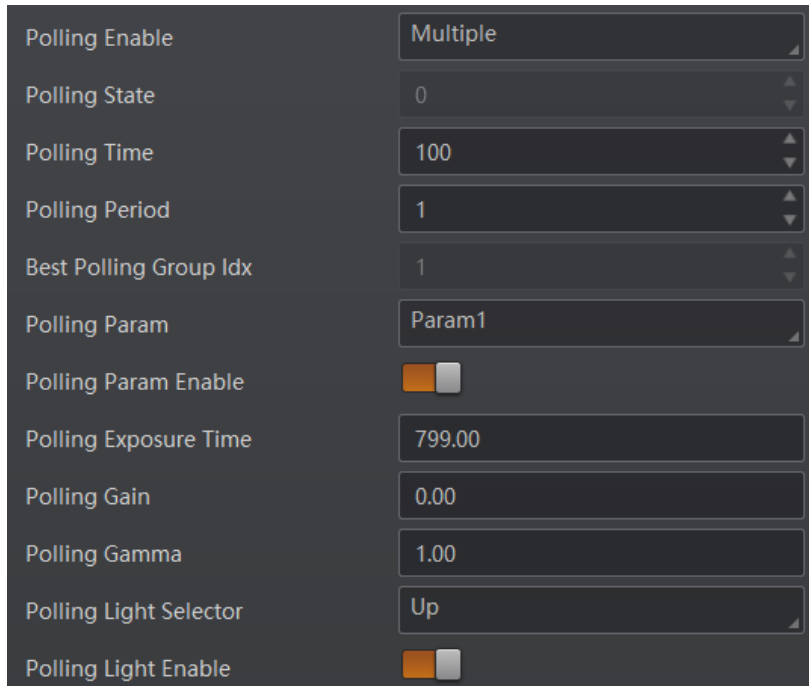

Figure 8-3 Multiple Mode

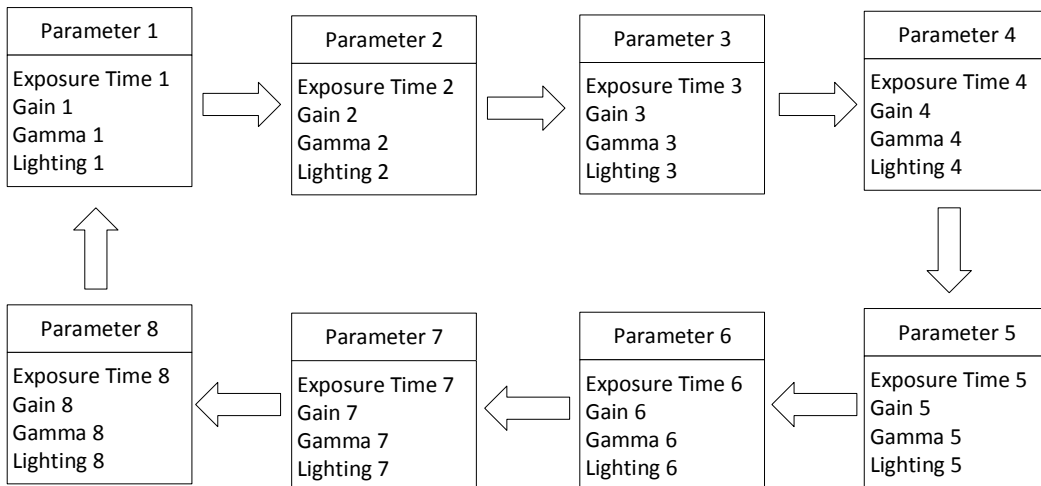

Figure 8-4 Polling Diagram

8.1.2 Set Light Source

You can select different light types, and set their related parameters in the light interface.

 **Note**

- Light source parameters may differ by device models.
- Make sure you have selected the device to be set in **Device Connection** before setting light source parameters.

You can select different light sources in **Light Type**.

Own Lighting

It refers to use the device's embedded light source to light during code reading.

External Lighting

It refers to the device controls the external light source by triggering output signal during code reading.

Non-Lighting

It refers to the device turns off light source during code reading.



Note

If you select **Non-Lighting** as **Light Type**, you do not need to set any parameters.

If you select **Own Lighting** as **Light Type**, you can set the following parameters.

Lighting Selector

You can click lamps on the light source illustration to turn on lamps on different directions like up, down, left and right. Check **All** to turn on all 8 lamps.

Light Mode

It has 2 light modes, including **Flash Strobe** and **Flash Long**. **Flash Strobe** means the light flashes at a specific interval during code reading, and **Flash Long** means the light is solid during code reading.

Lighting Duration

It sets the lighting duration and the unit is μs .

Lighting Delay Time



This parameter is available only when you set **Flash Strobe** as the **Light Mode**.

It determines the delay time for lighting after exposure and the unit is μs .

Lighting Ahead Time

It determines how earlier the light source starts lighting before exposure and the unit is μs .

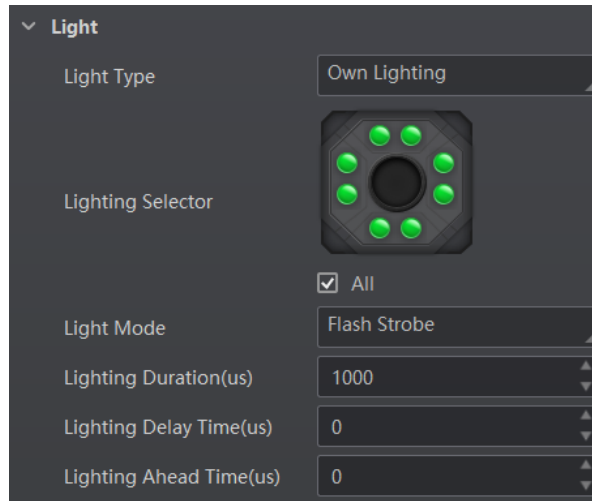

Figure 8-5 Light Parameters

If you select **External Lighting** as **Light Type**, you can set the following parameters.

Line Out Duration

The lighting duration of the external light source and the unit is μs .

Line Out Delay Time

It sets the delay time for lighting after the device outputs event source information, and the unit is μs .

Line Out Ahead Time

It sets how earlier the external light starts lighting before the device outputs event source information, and the unit is μs .

8.1.3 Set Auto Focus

The device supports setting lens focus via the client software. 2 ways are available to set lens focus, including auto focus and manual focus. Here we take auto focus as an example to introduce lens focus setting.

Steps

Note

- The lens focus function may differ by device models.
 - Setting the camera mode as **Test** is required before setting lens focus. After completion, you can set the camera mode as **Normal**.
-

1. Click  in the live view window.
2. Go to **Image Settings** → **Auto Focus**, and click **Execute** in **Focus Mode**.
The device starts to adjust focus automatically.

3. Select the position parameter from **Focus Position**, and click **Execute** in **Focus Position Save** to save the focus position.
4. (Optional) Select the position parameter from **Focus Position**, and click **Execute** in **Focus Position Load** to load saved focus position.

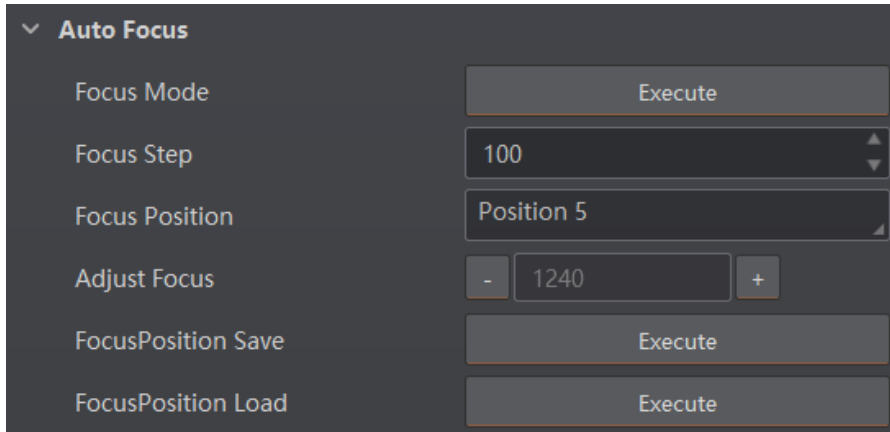

Figure 8-6 Set Auto Focus

8.1.4 Set Mirror X

The device supports the mirror X function. If this function is enabled, the image will be reversed in a horizontal way.

Go to **Image Settings**, click **All Features**, and you can see the **Mirror X**.

Note

This function is enabled by default, and it may differ by device models.

8.1.5 Set Test Pattern

Test pattern helps troubleshooting image problems and images in the test pattern are only for test. When exceptions occur in images acquired by the device in real time, you can check if images in the test pattern have similar problems to determine the cause of an exception.

Note

- The test pattern is available in the test or raw camera mode.
 - Specific parameters of this function may differ by device models.
-

Go to **Image Settings**, click **All Features**, find **Test Pattern** in **Other Features**, and set **Test Pattern** according to actual demands.

8.2 Barcode Algorithm Settings

The code reader supports reading multiple types of 1D code and 2D code, and you can add and set code parameters via the client software.

8.2.1 Add Barcode

Adding barcode before you set code parameters via the client software. In **Algorithm Settings**, you can add different types of barcodes, including Code 39, Code 93, Code 128, CodaBar, EAN, ITF 25, MATRIX 25, MSI, Industrial 25, China Post, QR Code, Data Matrix, etc.

In **Algorithm Settings**, click **Add Barcode**, select the types of barcodes to be read, and set the **1D Code Number** and **2D Code Number** according to actual demands.

Note

- For different models of the camera, the specific parameters may differ, and the actual device you purchased shall prevail.
 - Selected symbology amount and added code amount may affect the code recognition time. Note that selecting more symbologies or adding more codes may consume more time to recognize codes in the image.
 - No matter 1D code, 2D code, up to 20 codes can be added at a time. Note that adding more codes may consume more time to recognize codes in the image. Therefore, the code number is recommended to be set according to the actual demands.
 - The device may output actual code number when the mismatch between the actual code number and the code number set in the client software occurs.
-

8.2.2 Set 1D Algorithm Parameter

Click **All Features** on the upper-right to display all algorithm parameters. In the **Algorithm Parameter** page, select **1DCode** as **Arithmetic Type**, and then you can set its corresponding parameters.

Note

- You should have selected at least one type of 1D code.
 - For different models of the camera, the specific parameters may differ, and the actual device you purchased shall prevail.
-

Timeout Value

Timeout value refers to the maximum running time of algorithm, and its unit is ms. The code reader will stop parsing the images and return results if the time is exceeded the waiting time configured.

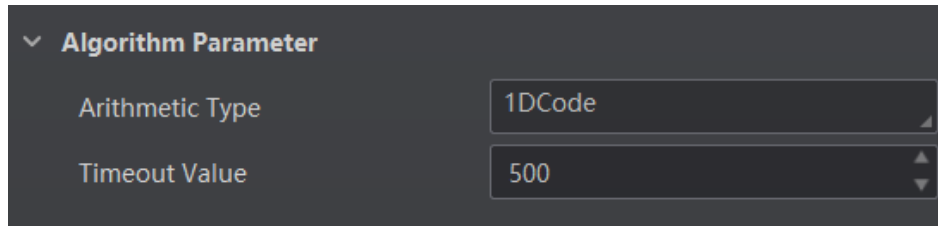

Figure 8-7 Set 1D Algorithm Parameter

8.2.3 Set 2D Algorithm Parameter

Click **All Features** on the upper-right to display all algorithm parameters. In the **Algorithm Parameter** page, select **2D Code** as **Arithmetic Type**, and then you can set its corresponding parameters.

Note

- You should have selected at least one type of 2D code.
 - For different models of the camera, the specific parameters may differ, and the actual device you purchased shall prevail.
-

Timeout Value

Timeout value refers to the maximum running time of algorithm, and its unit is ms. The code reader will stop parsing the images and return results if the time is exceeded the waiting time configured.

Algorithm Running Mode

It is used to be set the algorithm operating mode. It includes **High Speed**, **High Performance**, and **Balance**. **High Speed** focuses on recognition speed, and the algorithm can recognize the barcode rapidly, while **High Performance** refers to the algorithm can recognize the barcode that has distortion, spot or white gap, but its recognition speed is slow. **Balance** refers to the algorithm makes a balance between speed and performance.

2D Code Max. Size

It refers to the max. recognizable code width. The 2D code will not be recognized if its width exceeds the configured value.

Mirror Mode

It is useful when the recognized image is a mirror one, mirroring in X coordinate. 3 modes are available: **Adaptive**, **Mirror**, and **Non Mirror**.

Downsampling Level

It refers to the pixel sample size that the code reader takes. Increasing this parameter will improve the code reading efficiency at the expense of code recognition rate.

 **Note**

Increasing this parameter value will improve the code reading efficiency at the cost of code recognition rate.

Code Color

It defines the readable code color. **Adaptive** means that the client software can recognize both the black code with white background, and the white code with black background. **White Code On Black Wall** means that the client software can recognize the white code with black background. **Black Code On White Wall** means that the client software can recognize the black code with white background.

 **Note**



- For QR code, the code color is determined by the color of the concentric square on it.  indicates that the code color is white, and  indicates that the code color is black.



Figure 8-8 White QR Code



Figure 8-9 Black QR Code

- For DM code, the code color is determined by the color of its "L" shaped sides. White "L" shaped sides indicate that the code color is white, and black "L" shaped sides indicate that the code color is black.







Figure 8-10 White DM Code



Figure 8-11 Black DM Code

Discrete Flag

Continuous stands for the minimum units in the "L" shaped sides of the DM code are continuous, or the minimum units in the concentric square like  or  in the QR code are continuous. Usually the continuous code uses squares as the minimum units.

Discrete stands for the minimum units in the "L" shaped sides of the DM code are discrete, or the minimum units in the concentric square like  or  in the QR code are discrete. Usually the discrete code uses dots as the minimum units.

Adaptive stands for the device can recognize both continuous code and the discrete code.

QR Distortion Correction

If the QR code or DM code is distorted, you can enable this parameter to improve code recognition rate.

Note

If you enable this parameter, the more time will be consumed to recognize the codes in the image.

Advance Param

This parameter is applicable to some special codes, and it is recommended to use the default value.

DM Code Shape

It defines the recognizable code shape. **Square** stands for square mode: If the 2D code is square shaped, it can be recognized by the device. **Rectangle** stands for rectangle mode: If the 2D code is rectangle shaped, it can be recognized by the device. **Adaptive** stands for compatible mode: The device can recognize 2D codes of both the above-mentioned two shapes.

Code Quality Evaluation Enable

If it is enabled, the device will evaluate the Data Matrix code quality and display overall grade and code score in the history record area of the client software. The higher the score, and the better the Data Matrix code quality.

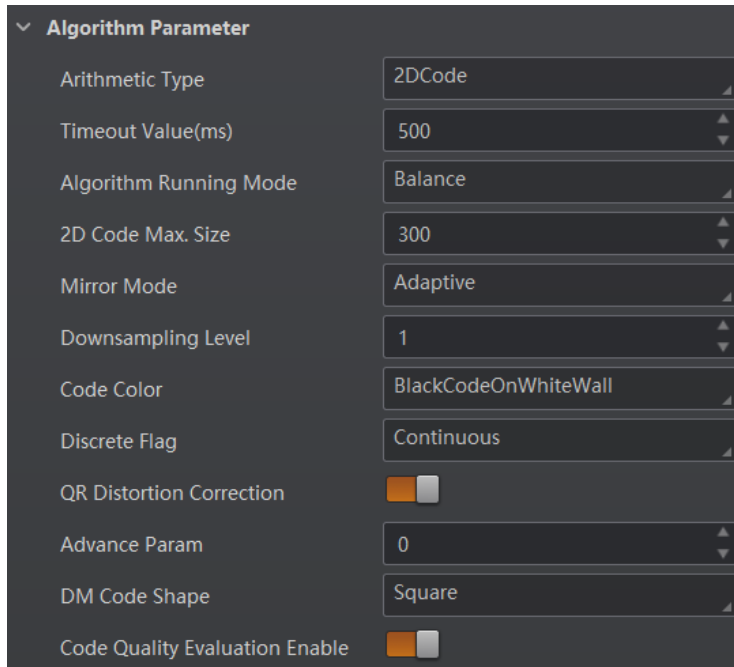

Figure 8-12 Set 2D Algorithm Parameter

8.2.4 Set Code Reading ROI

Algorithm ROI (Region of Interest) allows the device to execute algorithms and read codes on the specific area you selected, and thus improving code reading efficiency. Currently, up to 20 ROIs can be configured, and the device outputs codes according to the number of ROI (e.g. Region 1, Region 2, Region 3) in turn.

Note

- If no code is recognized in the algorithm ROI, and the device will output “noread”.
 - If no algorithm ROI is enabled, and the full screen is the algorithm ROI by default.
 - This function may differ by device models.
-

Go to **Algorithm Settings**, click **All Features**, find **Algorithm ROI**, select ROI from **ROI Selector**, and enable **ROI Enable**.

Click **Draw** to draw the ROI in the live view window, or set **Draw ROI Width**, **Draw ROI Height**, **Draw ROI Offset X** and **Draw ROI Offset Y** according to actual demands, and you can right click the drawn ROI, and click **Delete** to delete it.

You can click **Execute** in **Restore Max. Algorithm ROI** to restore the ROI to the full screen.

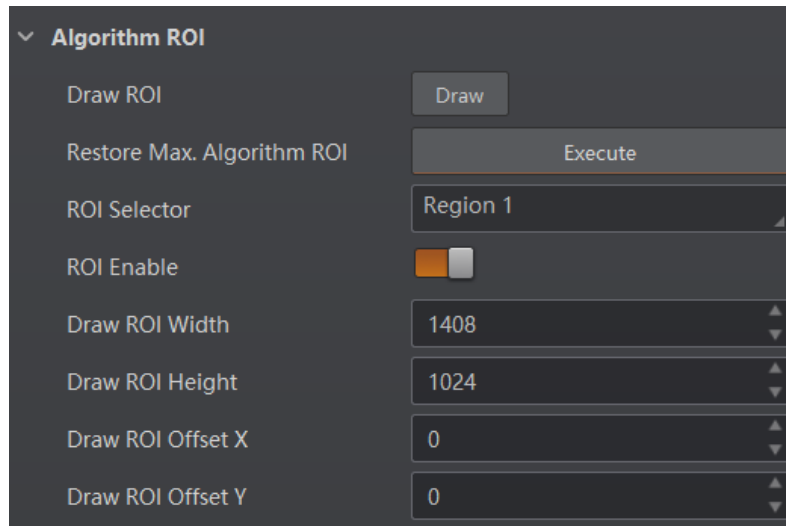

Figure 8-13 Set Code Reading ROI

8.3 Signal Input Settings

In the signal input module, you can set the trigger related parameters. You can enable trigger mode to let the acquisition of image data occur only when the trigger source is generated.

8.3.1 Set Trigger Mode

The camera has 2 types of trigger mode: Internal trigger mode and external trigger mode.

Internal Trigger Mode

In this mode, the camera acquires images via its internal signals.

External Trigger Mode

In this mode, the camera acquires images via external signals like software signal and hardware signal. The trigger source of external trigger mode includes software, physical lines, counter, TCP, UDP, and serial.

8.3.2 Enable Internal Trigger Mode

In the internal trigger mode, the camera acquires images via its internal signals. You have 2 methods to enable the internal trigger mode:

- Click **I/O Control Settings** → **Input** → **Trigger Mode**, and select **Off** as **Trigger Mode**.
- In the live view page, click  to enable the internal trigger mode.

8.3.3 Enable External Trigger Mode

In the external trigger mode, the camera acquires images via external signals like software signal and hardware signal. You have 2 methods to enable the external trigger mode:

- Click **I/O Control Settings** → **Input** → **Trigger Mode**, and select **On** as **Trigger Mode**.
- In the live view page, click  to enable the external trigger mode.

Set and Execute Software Trigger Mode

In software trigger, the software sends trigger signal to the camera via I/O interface to acquire images.

Steps

1. Click **I/O Control Settings** → **Input** → **Trigger Mode**.
2. Select **On** as **Trigger Mode**.
3. Select **Software** as **Trigger Source**.
4. Click **Execute** in **Trigger Source** to send trigger commands.

You can also enter **Auto Trigger Time**, and then enable **Enable Auto Trigger** to let the client software automatically send trigger signal to camera according to the interval you set.

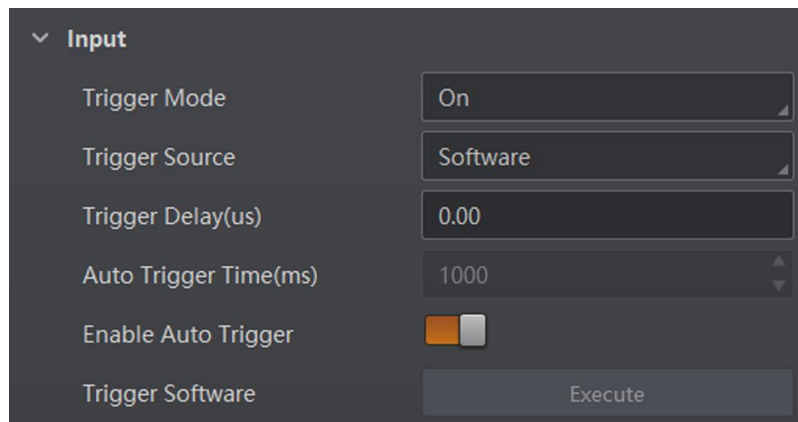

Figure 8-14 Set and Execute Software Trigger Mode

Set and Execute Hardware Trigger Mode

Steps

1. Click **I/O Control Settings** → **Input** → **Trigger Mode**.
2. Select **On** as **Trigger Mode**.
3. Select the specific line as **Trigger Source** according to actual demands.
4. Set **Debounce Time** and **Line Out Trigger In Polarity** according to actual demands.

Note

- When selecting **Rising Edge** or **Falling Edge** as **Line Out Trigger In Polarity**, you can set **Trigger Delay**.
 - When selecting **Level High** or **Level Low** as **Line Out Trigger In Polarity**, you can set **Start Delay Time** and **End Delay Time** according to actual demands.
-

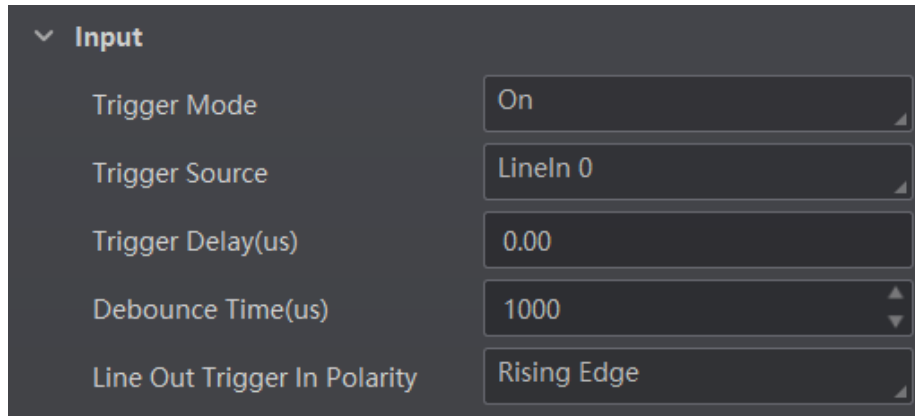

Figure 8-15 Set and Execute Hardware Trigger Mode

Set and Execute Counter Trigger Mode

Counter specifies that the trigger source will be generated after the set number of valid signals appears. For example, if you set the **Count Number** to **3**, the trigger source will be generated after 3 signals appear.

Steps

1. Click **I/O Control Settings** → **Input** → **Trigger Mode**.
2. Select **On** as **Trigger Mode**.
3. Select **Counter 0** as **Trigger Source**.
4. Set **Trigger Delay**, **Count Number**, **Count Source** and **Line Out Trigger In Polarity** according to actual demands.

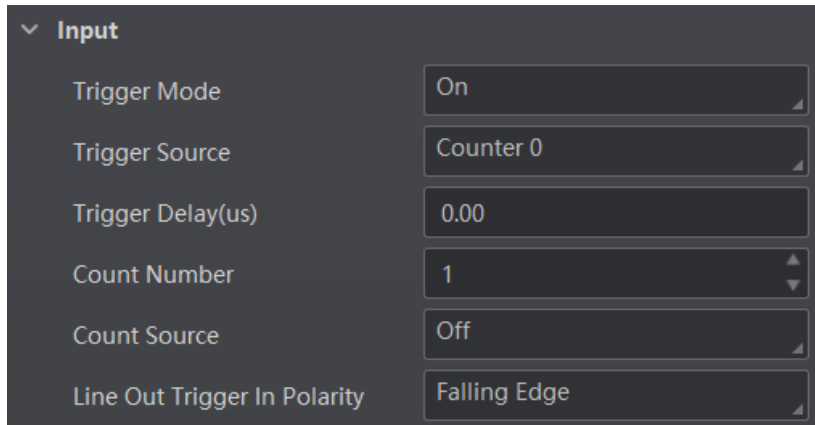

Input	
Trigger Mode	On
Trigger Source	Counter 0
Trigger Delay(us)	0.00
Count Number	1
Count Source	Off
Line Out Trigger In Polarity	Falling Edge

Figure 8-16 Set and Execute Counter Trigger Mode

Set and Execute TCP Trigger Mode

TCP start specifies the TCP server as the source for the trigger signal. When the server receives the specified string text, the trigger signal will be outputted.

Click **I/O Control Settings** → **Input** → **Trigger Mode**, select **On** as **Trigger Mode** and select **TCP Start** as **Trigger Source**.

Set **Trigger Delay**, **Tcp Trigger Port**, and **Tcp Start Trigger Text** according to actual demands.

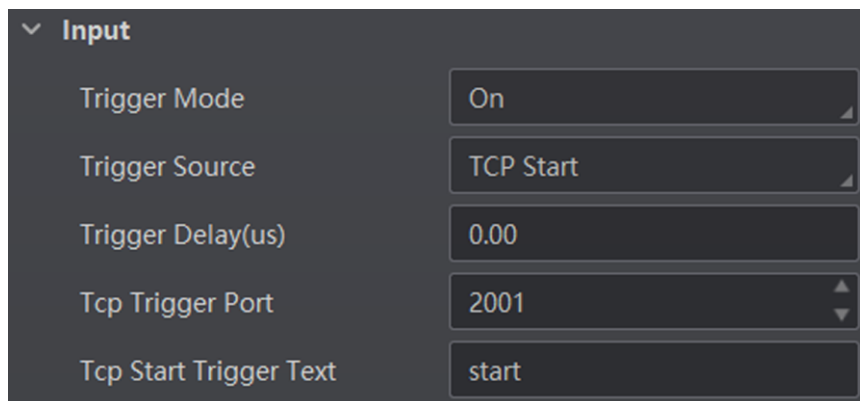

Input	
Trigger Mode	On
Trigger Source	TCP Start
Trigger Delay(us)	0.00
Tcp Trigger Port	2001
Tcp Start Trigger Text	start

Figure 8-17 Set and Execute TCP Trigger Mode

Set and Execute UDP Trigger Mode

UDP start specifies the UDP server as the source for the trigger signal. When the server receives the specified string text, the trigger signal will be outputted.

Click **I/O Control Settings** → **Input** → **Trigger Mode**, select **On** as **Trigger Mode** and select **UDP Start** as **Trigger Source**.

Set **Trigger Delay**, **Udp Trigger Port**, and **Udp Start Trigger Text** according to actual demands.

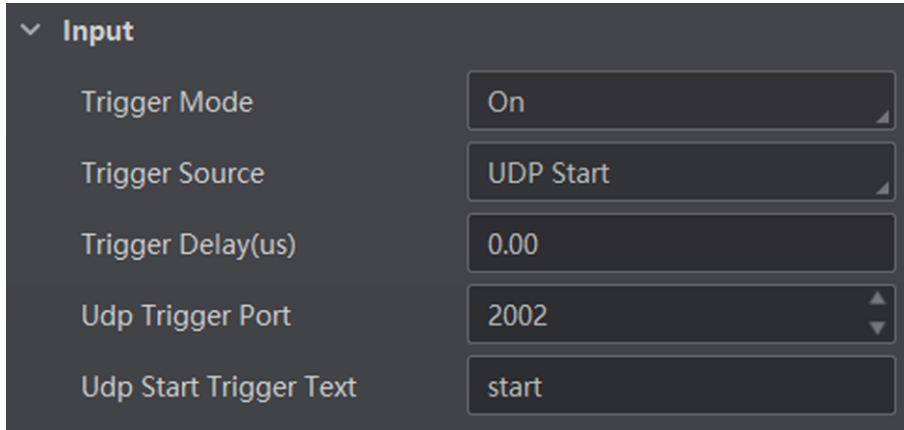

The screenshot shows a dark-themed settings menu with a dropdown arrow on the left labeled 'Input'. The settings are as follows:

Setting	Value
Trigger Mode	On
Trigger Source	UDP Start
Trigger Delay(us)	0.00
Udp Trigger Port	2002
Udp Start Trigger Text	start

Figure 8-18 Set and Execute UDP Trigger Mode

Set and Execute Serial Port Trigger Mode

Serial start specifies the serial port as the source for the trigger signal. When the serial port receives the specified string text, the trigger signal will be outputted.

Click **I/O Control Settings** → **Input** → **Trigger Mode**, select **On** as **Trigger Mode** and select **Serial Start** as **Trigger Source**.

Set **Trigger Delay**, **Serial Baudrate**, **Serial Data Bits**, **Serial Parity**, **Serial Stop Bits**, and **Serial Start Trigger Text** according to actual demands.

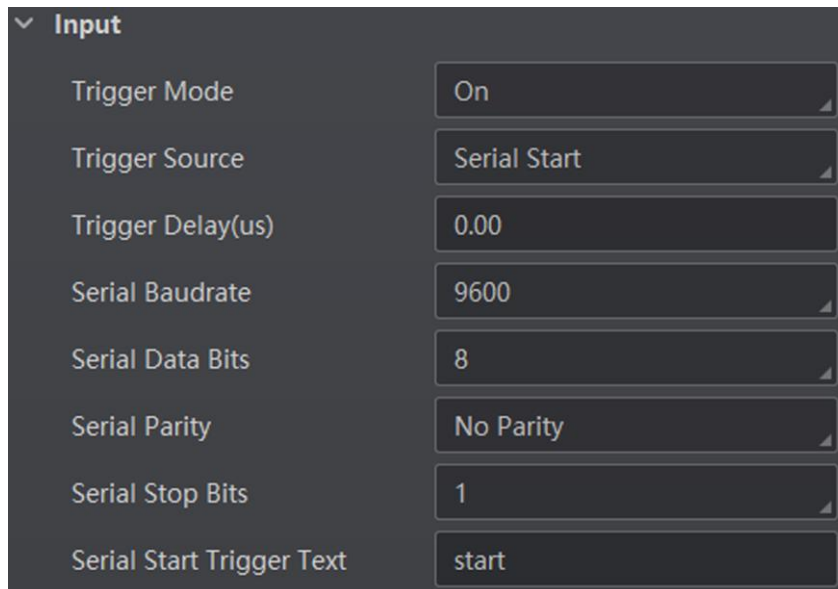

The screenshot shows a dark-themed settings menu with a dropdown arrow on the left labeled 'Input'. The settings are as follows:

Setting	Value
Trigger Mode	On
Trigger Source	Serial Start
Trigger Delay(us)	0.00
Serial Baudrate	9600
Serial Data Bits	8
Serial Parity	No Parity
Serial Stop Bits	1
Serial Start Trigger Text	start

Figure 8-19 Set and Execute Serial Port Trigger Mode

8.3.4 Stop Trigger

The device supports stopping trigger via TCP, UDP, I/O, and serial port. You can also set code reading timeout duration or max. barcode amount to be read to stop trigger. After stopping trigger is

completed, the device cannot make response to trigger again.

Stop Trigger via IO

You can stop a trigger via IO: Enabling **IO Stop Trigger Enable** first, select specific sources from **IO Stop Trigger Selector**, and then set the trigger polarity as the condition to stop trigger.

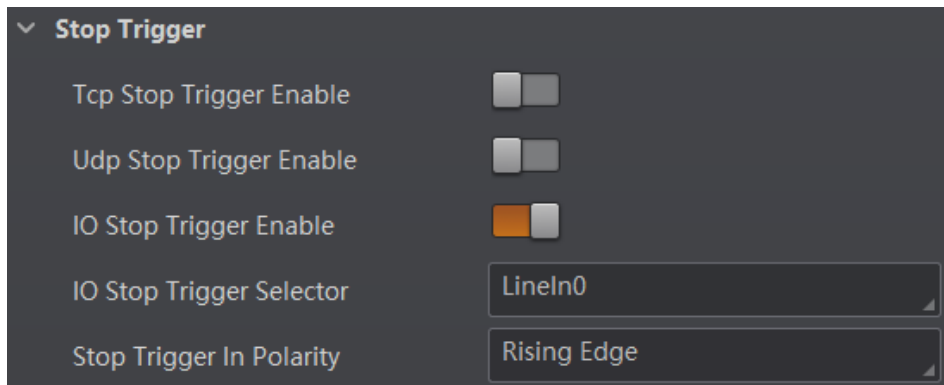

Figure 8-20 Stop Trigger via IO

When selecting **SoftwareTriggerEnd** as **IO Stop Trigger Selector**, you can click **Execute** in **Software Stop Trigger** to stop current trigger.

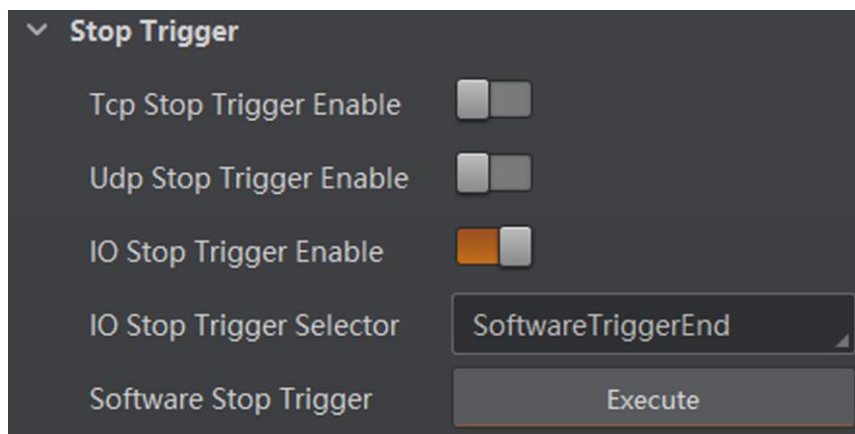

Figure 8-21 Software Trigger End

Stop Trigger via Serial

When the specified serial port receives the specified string text, the trigger will be stopped. The client software sends stop trigger command to the device after **Serial Stop Trigger Enable** is enabled.

You should enter **Serial Stop Trigger Text**, **Serial Baudrate**, **Serial Data Bits**, **Serial parity**, and **Serial Stop Bits** according to actual demands. The **Serial Baudrate** includes **4800**, **9600**, **19200**, **38400**, **57600** and **115200**, and **Serial Data Bits** is **8**.

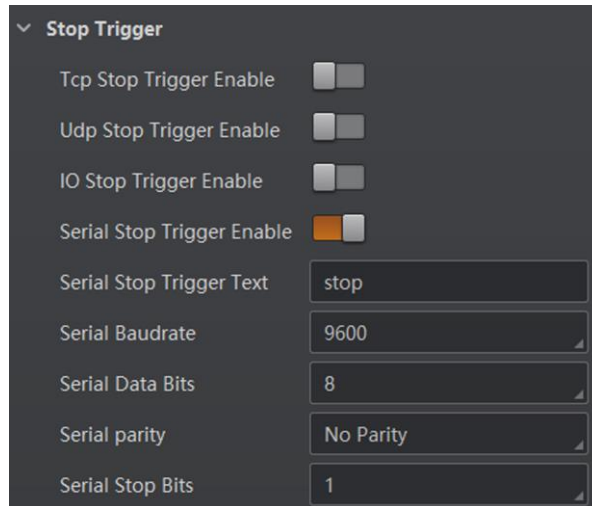

Figure 8-22 Stop Trigger via Serial

Stop Trigger via UDP

When the UDP server receives the specified string text, the trigger will be stopped. The client software sends stop trigger command to the device after **Udp Stop Trigger Enable** is enabled. You should enter **Udp Trigger Port** and **Udp Stop Trigger Text** according to actual demands. The range of **Udp Trigger Port** is from **1025** to **65535**, and the default port is **2002**.

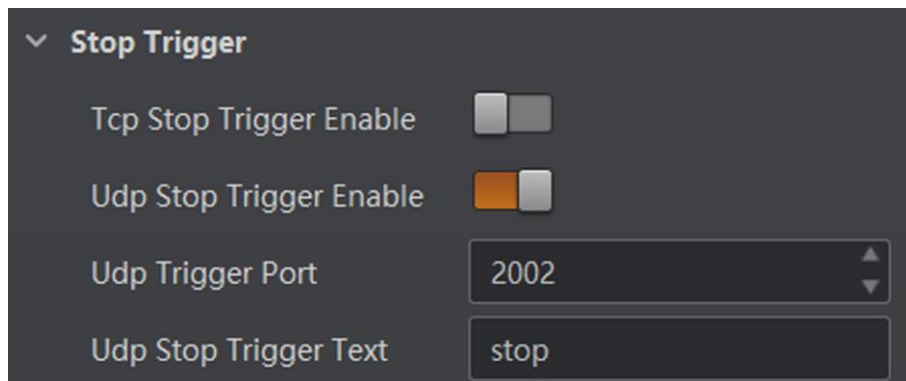

Figure 8-23 Stop Trigger via UDP

Stop Trigger via TCP

When the TCP server receives the specified string text, the trigger will be stopped. The client software sends stop trigger command to the device after **Tcp Stop Trigger Enable** is enabled. You should enter **Tcp Trigger Port** and **Tcp Stop Trigger Text** according to actual demands. The range of **Tcp Trigger Port** is from **1025** to **65535**, and the default port is **2001**.

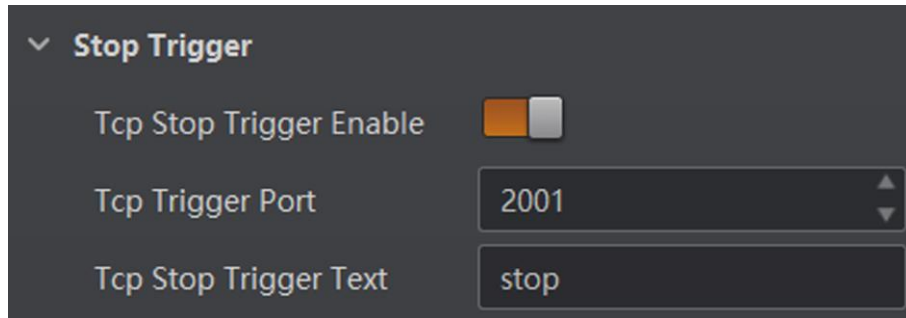

Figure 8-24 Stop Trigger via TCP

Stop Trigger via Timeout Duration

Note

TimeOut Stop Trigger Enable is only available when the camera mode is set to **Normal** and the **Trigger Mode** is **On**.

When the trigger time reaches the specified maximum value (in ms), the trigger will be stopped. You can enable **TimeOut Stop Trigger Enable**, and set **Maximum Output Limited Time** according to actual demands. The range of **Maximum Output Limited Time** is 0 to 10000 ms.

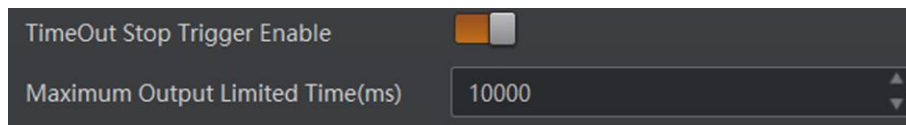

Figure 8-25 Stop Trigger via Timeout Duration

Stop Trigger via Code Number

Note

CodeNum Stop Trigger Enable is only available when the camera mode is set to **Normal** and the **Trigger Mode** is **On**.

This function means that the code quantity outputted by the device is restricted to the settings you configured here. You can enable **CodeNum Stop Trigger Enable**, and set **CodeNum Stop Trigger Min** and **CodeNum Stop Trigger Max** according to actual demands.

- If the outputted code quantity is smaller than configured **CodeNum Stop Trigger Min**, and the device will output codes continuously.
- If the outputted code quantity is smaller than configured **CodeNum Stop Trigger Max**, and the device will stop outputting codes.
- If the outputted code quantity is between configured **CodeNum Stop Trigger Min** and **CodeNum Stop Trigger Max**, and the device will read and output codes according to trigger signals.
- If **CodeNum Stop Trigger Min** is same with **CodeNum Stop Trigger Max**, and the device will stop

outputting codes when the number of outputted codes reaches the configured number.

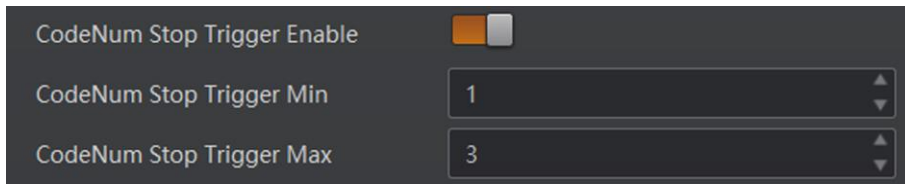

Figure 8-26 Stop Trigger via Code Number

8.4 Signal Output Settings

8.4.1 Select Output Signal

The device's output signal can control external devices like PLC, flashing light, etc. Click **I/O Control Settings** → **Output** → **Line Out Selector** to select output signal.

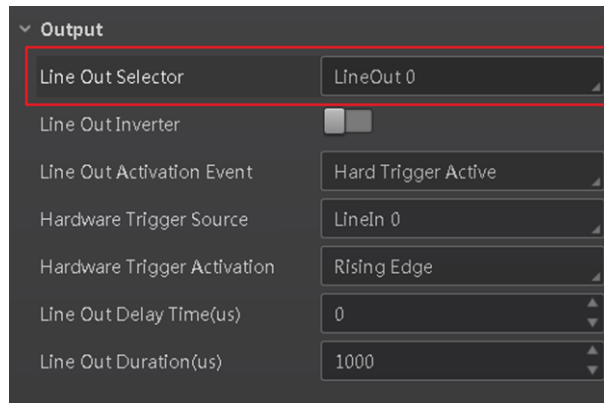

Figure 8-27 Select Output Signal

8.4.2 Enable Line Inverter

The level inverter function allows the camera to invert the electrical signal level of an I/O line, and meets requirements of different devices for high or low electrical signal level.

You can go to **I/O Control Settings** → **Output** → **Line Out Inverter** to enable it.

Note

The **Line Out Inverter** function is disabled by default.

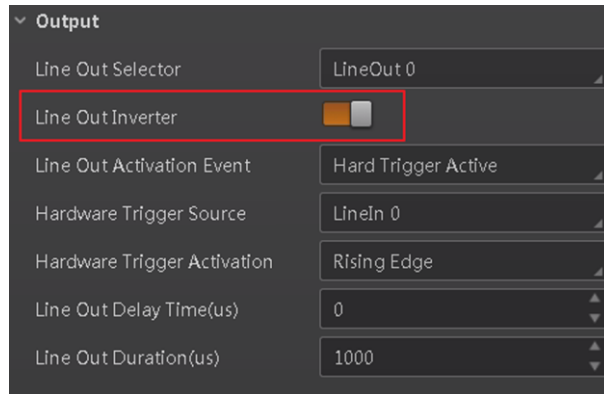

Figure 8-28 Enable Line Out Inverter

8.4.3 Set Event Source

The device supports outputting different trigger signals according to the event source you select. Click **I/O Control Settings** → **Output** → **Line Out Activation Event** to select event source.

The device supports following event sources, including **Off**, **Acquisition Start Active**, **Acquisition Stop Active**, **Frame Burst Start Active**, **Frame Burst Stop Active**, **Exposure Start Active**, **Soft Trigger Active**, **Hard Trigger Active**, **Counter Active**, **Timer Active**, **No Code Read**, **Read Success**, and **Light Strobe Long**.

Note

You need to set different parameters when selecting these event sources.

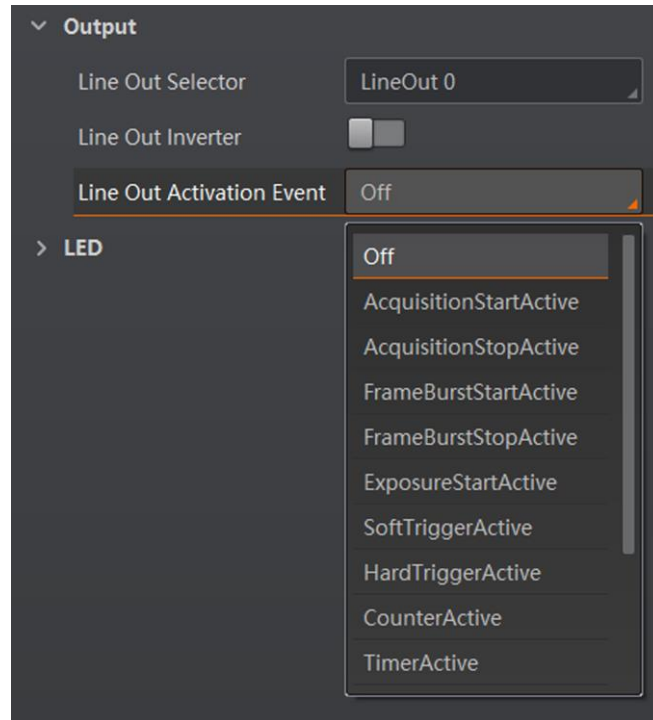

Figure 8-29 Set Event Source

Select Acquisition Start Active

If acquisition starts, the output signal will be triggered. When you select **Acquisition Start Active** as **Line Out Activation Event**, you can set its output delay time and duration.

Line Out Delay Time

It sets the delay time for outputting the output signal.

Line Out Duration

It sets the time duration of the output signal.

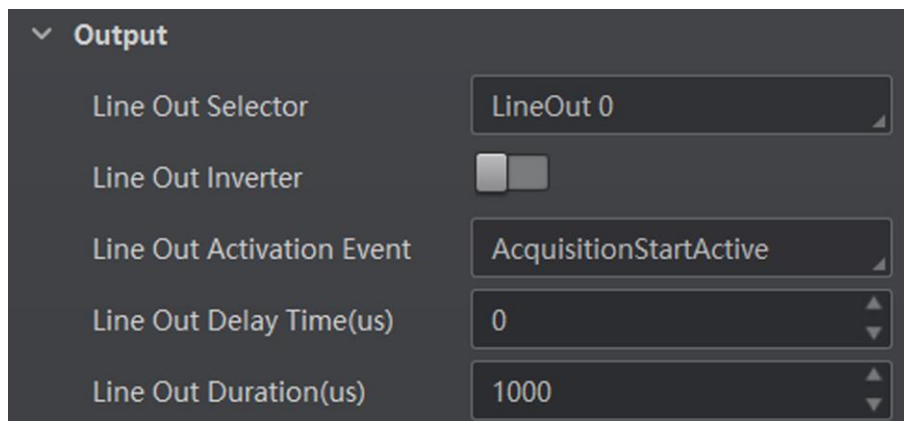

Figure 8-30 Select Acquisition Start Active

Select Acquisition Stop Active

If acquisition stops, the output signal will be triggered. When you select **Acquisition Stop Active** as **Line Out Activation Event**, you can set its output delay time and duration.

Line Out Delay Time

It sets the delay time for outputting the output signal.

Line Out Duration

It sets the time duration of the output signal.

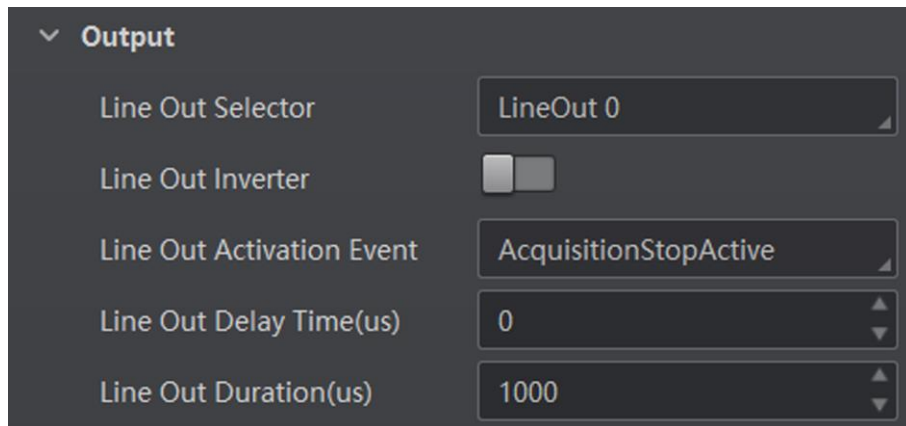

Figure 8-31 Select Acquisition Stop Active

Select Frame Burst Start Active

Note

The **Frame Burst Start Active** is not supported when the trigger polarity is level high or level low.

If the burst of a frame starts, the output signal will be triggered. When you select **Frame Burst Start Active** as **Line Out Activation Event**, you can set its output delay time and duration.

Line Out Delay Time

It sets the delay time for outputting the output signal.

Line Out Duration

It sets the time duration of the output signal.

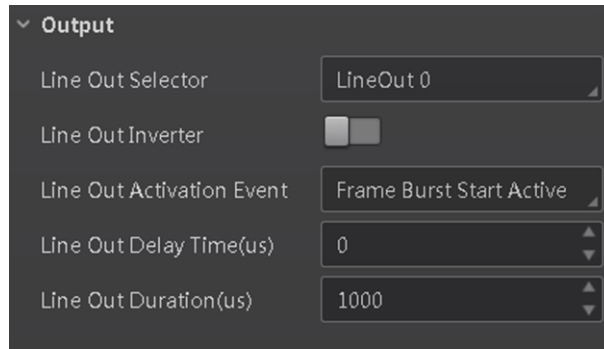

Figure 8-32 Select Frame Burst Start Active

Select Frame Burst Stop Active

 **Note**

The **Frame Burst Stop Active** is not supported when the trigger polarity is level high or level low.

If the burst of a frame stops, the output signal will be triggered. When you select **Frame Burst Stop Active** as **Line Out Activation Event**, you can set its output delay time and duration.

Line Out Delay Time

It sets the delay time for outputting the output signal.

Line Out Duration

It sets the time duration of the output signal.

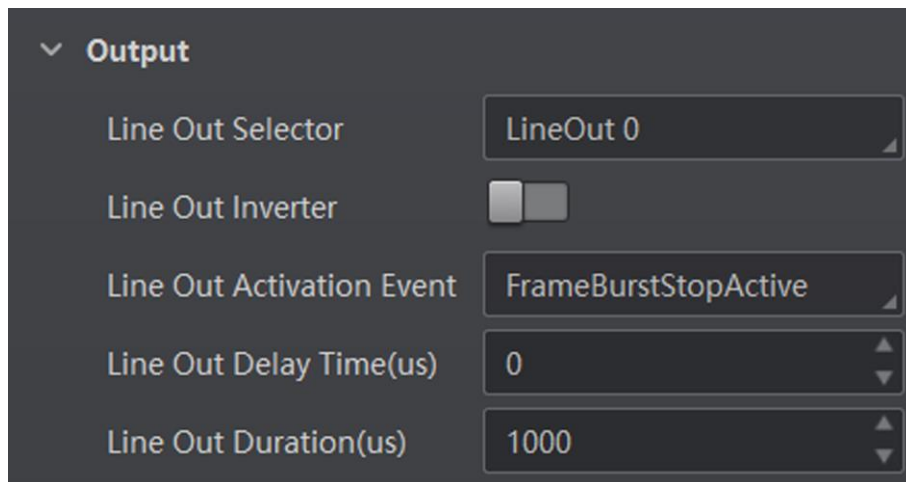

Figure 8-33 Select Frame Burst Stop Active

Select Exposure Start Active

Note

For different models of camera, when selecting **Exposure Start Active** as **Line Out Activation Event**, the specific parameters may be different. The actual product you purchased shall prevail.

If you select **Exposure Start Active** as **Line Out Activation Event**, you can set its output delay time, duration, and ahead time.

Line Out Delay Time

It sets the delay time for outputting the signal.

Line Out Duration

It sets the duration for outputting the signal.

Line Out Ahead Time

It sets the ahead time for outputting the signal.

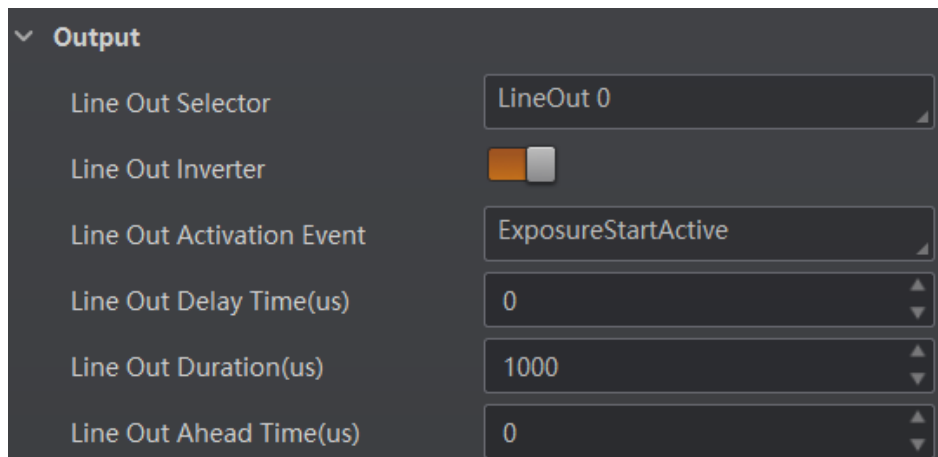

Figure 8-34 Select Exposure Start Active

Select Soft Trigger Active

If you select **Soft Trigger Active** as **Line Out Activation Event**, you can set its output delay time, duration, and execute outputting signal manually.

Line Out Delay Time

It sets the delay time for outputting the output signal.

Line Out Duration

It sets the time duration of the output signal.

Line Trigger Software

Click **Execute** for manually outputting the output signal.

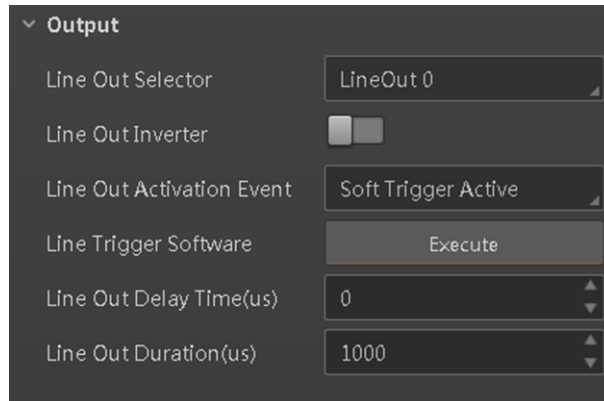

Figure 8-35 Select Soft Trigger Active

Select Hard Trigger Active

If you select **Hard Trigger Active** as **Line Out Activation Event**, you can set its output delay time, duration, trigger source, and trigger activation.

Line Out Delay Time

It sets the delay time for outputting the output signal.

Line Out Duration

It sets the time duration of the output signal.

Hardware Trigger Source

It sets the hardware trigger source, including **LineIn 0**, **LineIn 1**, and **LineIn 2**.

Hardware Trigger Activation

It sets the trigger activation of input signal, including **Rising Edge** and **Falling Edge**.

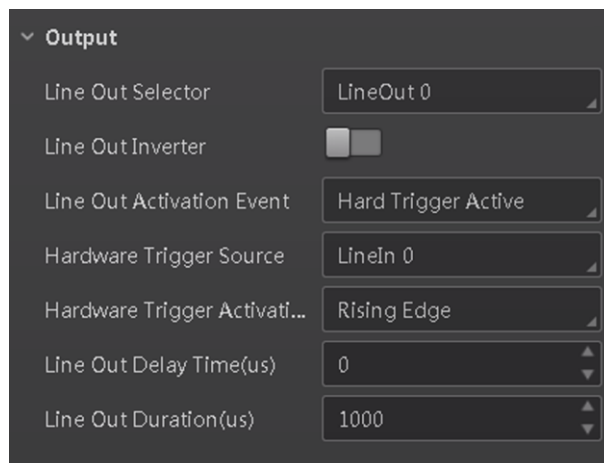

Figure 8-36 Select Hard Trigger Active

Select Counter Active

Counter active means that the counter triggers the output signal. When you select **Counter Active** as **Line Out Activation Event**, you can set its output delay time and duration.

Line Out Delay Time

It sets the delay time for outputting the output signal.

Line Out Duration

It sets the time duration of the output signal.

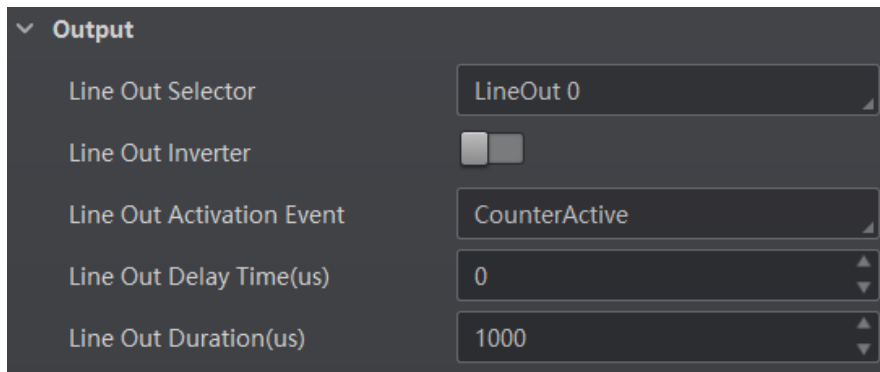

Figure 8-37 Select Counter Active

Select Timer Active

If you select **Timer Active** as **Line Out Activation Event**, you can set its output duration and period.

Line Out Duration

It sets the time duration of the output signal.

Line Out Period

It sets the time period of the output signal.

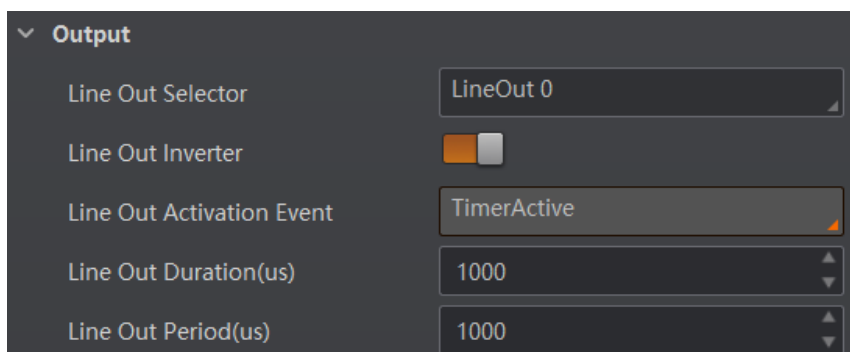

Figure 8-38 Select Timer Active

Select No Code Read

If you select **No Code Read** as **Line Out Activation Event**, you can set its output delay time and duration.

Line Out Delay Time

It sets the delay time for outputting the output signal.

Line Out Duration

It sets the time duration of the output signal.

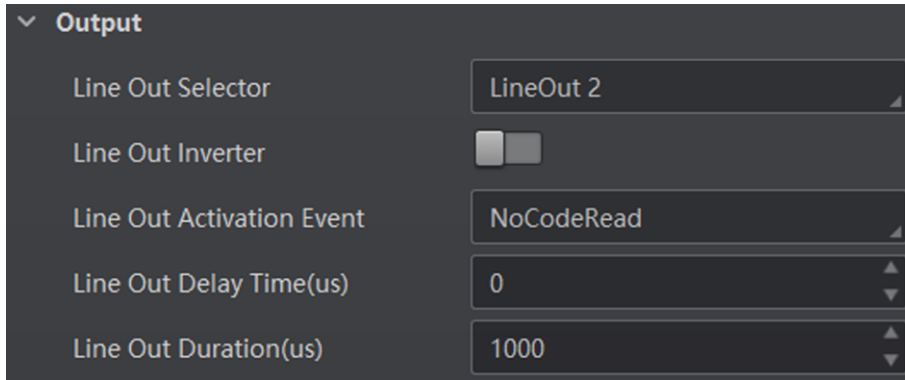

Figure 8-39 Select No Code Read

Select Read Success

If you select **Read Success** as **Line Out Activation Event**, you can set its output delay time and duration.

Line Out Delay Time

It sets the delay time for outputting the output signal.

Line Out Duration

It sets the time duration of the output signal.

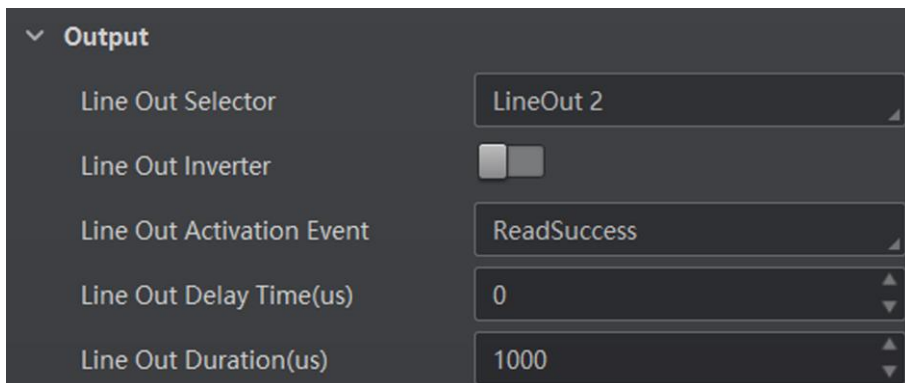

Figure 8-40 Select Read Success

Select Light Strobe Long

If you select **Light Strobe Long** as **Line Out Activation Event**, you do not need to set any parameters.

8.5 Code Reading Result Settings

In **Data Processing** module, you can set filter rules for reading barcodes and other data processing related parameters.

8.5.1 Set Code Reading Result Output Mode

There are 2 types of output modes when the camera mode is **Normal** and trigger mode is **On**: Instant output mode and non-instant output mode.

- Instant output mode means that the device can instantly output code reading results when recognizing codes if you enable **Instant Output Mode Enable** in **Filter Rule**.
- Non-instant output mode means that the device does not output code reading results it recognized until the trigger stops if **Instant Output Mode Enable** is not enabled. If the device does not recognize any codes during the whole process, images it captured will be output, and you can set which images to be outputted in **NoRead Image Index**.

When the camera mode is **Normal** and trigger mode is **Off**, you can set **Filter Time** in **Filter Rule**. Within the configured **Filter Time**, the device will not output any code information.

Note

The filter rule and data processing parameters may differ with different camera modes and trigger modes.

8.5.2 Set Filter Rule

You can set rules to filter unwanted barcodes to improve the reading efficiency in **Filter Rule**.

Note

The filter rule parameters may differ with different camera modes and trigger modes.

When the camera mode is **Normal** and **Trigger Mode** is **On**, you can set the following parameters according to actual demands.

Instant Output Mode Enable

If this parameter is enabled, the device can instantly output code reading result when recognizing codes. If it is not enabled, the device will not output code reading result until the trigger stops.

Minimum Output Time

It sets the min. waiting time before data output. For example, if you set 500 ms as **Minimum Output Time**, the barcode would not be outputted until 500 ms is passed.

Min. Code Length

If the length of a barcode is shorter (in terms of the number of characters contained in the barcode) than the configured value, the device will not parse the contents of the barcode. The valid value is from 1 to 256. For example, if you set the value as 6, the device will not parse the contents of the barcodes which contain less than 6 characters.

Max. Code Length

If the length of a barcode is longer ((in terms of the number of characters contained in the barcode) than the configured value, the device will not parse the contents of the barcode. The valid value is from 1 to 256. For example, if you set the value as 9, the device will not parse the contents of the barcodes which contain more than 9 characters.

Numeral Filter

If this parameter is enabled, the device will only parse and read the numeral contents of the barcodes, and the non-numeral contents will be filtered out.

CodeLen Max Num

It sets the max. length of barcode that can be output.

Code Offset Num

It sets the range of barcode to be filtered. For example, the barcode is ABCDEFG, if you set this parameter as 2, the device will output CDEFG at last and filter AB.

Begin with Specific Character for Result

If this parameter is enabled, the device will only read the barcodes which begin with a specific character. Otherwise, the barcodes will be filtered out. You can enter the specific character in **Begin with**.

Include Specific Character in Barcode

If this parameter is enabled, the device will only read the barcodes which include a specific character. Otherwise, the barcodes will be filtered out. You can enter the specific character in **Character**.

Exclude Specific Character in Barcode

If this parameter is enabled, the device will only read the barcodes which exclude a specific character. Otherwise, the barcodes will be filtered out. You can enter the specific character in **Character**.

Regular Expression Filter Enable

If this parameter is enabled, the device will only read the barcodes which contain a specific regular expression. You can enter the specific regular expression in **Regular Expression Filter**.

NoRead TimeOut

If no barcodes are not recognized after the time you set here, the client software will output NoRead instead.

Read Times Threshold

If the reading results of a barcode is same for the configured times, the barcode will be regarded as valid and its reading result will be outputted. Or the barcode will be regarded as invalid and its reading result will not be outputted.

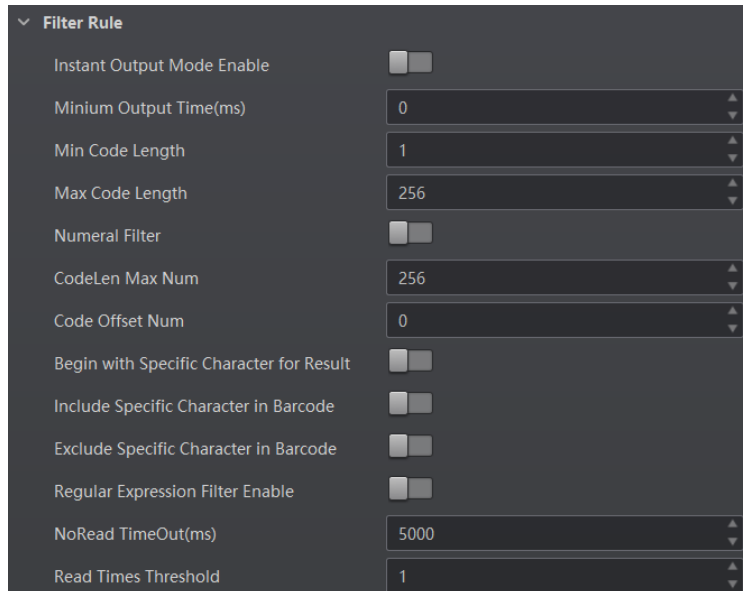

Figure 8-41 Set Filter Rule

8.5.3 Set Result Format

Result format settings allow you to set the format and contents contained in the outputted barcode information. Result format is related to communication protocol and trigger mode. With different selected communication protocol and trigger mode, you need to set corresponding parameters.

Note

- Result format settings are only available if you select **TCP Client**, **TCP Server**, **Serial**, **FTP**, **Profinet**, **Melsec**, **Ethernet/IP**, or **ModBus** as the communication protocol when the camera mode is **Normal**. Result format settings are not available for **Smart SDK** and **HTTP**.
 - For details about communication protocol, see section **Communication Settings** for details.
-

Result Output via Smart SDK

When the communication protocol is **Smart SDK**, camera mode is **Normal** and trigger mode is **On**, you just need to set **NoRead Image Index** in the **Data Processing**.

 **Note**

When the communication protocol is **Smart SDK**, camera mode is **Normal** and trigger mode is **Off**, you do not need to set any parameter.

NoRead Image Index

It sets the specific image that is outputted when no barcode information is read. For example, if you set this parameter as 5, and the 5th image will be output.

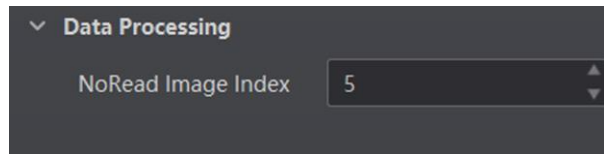

Figure 8-42 Result Output via Smart SDK

Result Output via TCP Client

If the device is used as a TCP client, it can connect, send, and receive data over the network. The configurable parameters below are related to the trigger mode, and here we take the external trigger mode as an example.

 **Note**

The configurable parameters may differ if the internal trigger mode is enabled.

ROI Output NoRead Enable

If it is enabled, codes will be outputted in turn according to the **ROI Selector** of the algorithm ROI they belong.

TCP Format Output Content

It selects what contents you want to output, including code content, code type, angle, trigger start time, code score, etc. You can select multiple contents as desired, and the selected contents will be displayed in **TCP Format String**. You are also allowed to directly enter contents in **TCP Format String**.

TCP Format Check

You should click **Execute** in **TCP Format Check** to check if you entered is right in format, and the check result will be displayed in **TCP Format Check Result**.

NoRead Image Index

It sets the specific image that is outputted when no barcode information is read. For example, if you set this parameter as 5, and the 5th image will be output.

TCP Output NoRead Enable

If it is enabled, and the device will output the content you set in **TCP Output NoRead Text** when no code is recognized.

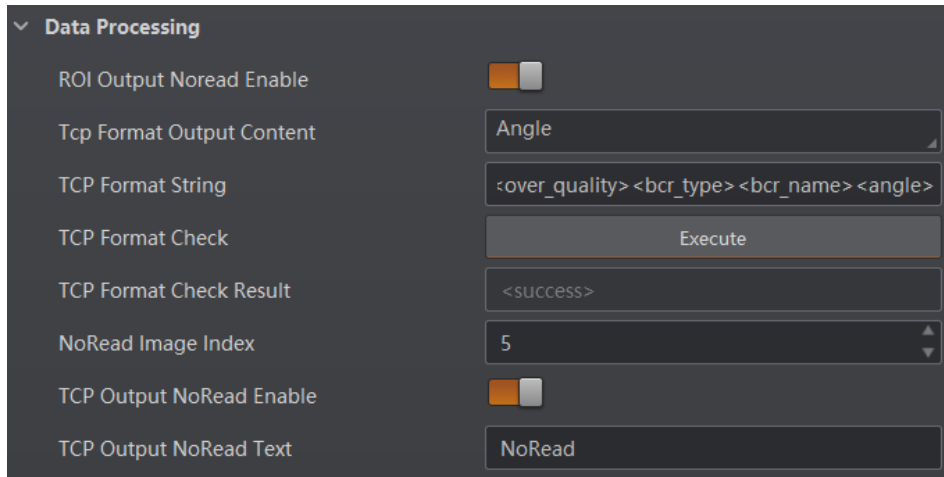

Figure 8-43 Result Output via TCP Client

Result Output via TCP Server

If the device is used as a TCP server, it can also connect, send, and receive data over the network. The configurable parameters below are related to the trigger mode, and here we take the external trigger mode as an example.

Note

The configurable parameters may differ if the internal trigger mode is enabled.

ROI Output NoRead Enable

If it is enabled, codes will be outputted in turn according to the **ROI Selector** of the algorithm ROI they belong.

TCP Server Format Output Content

It selects what contents you want to output, including code content, code type, angle, trigger start time, code score, etc. You can select multiple contents as desired, and the selected contents will be displayed in **TCP Server Format String**. You are also allowed to directly enter contents in **TCP Server Format String**.

TCP Server Format Check

You should click **Execute** in **TCP Server Format Check** to check if you entered is right in format, and the check result will be displayed in **TCP Server Format Check Result**.

NoRead Image Index

It sets the specific image that is outputted when no barcode information is read. For example, if you set this parameter as 5, and the 5th image will be output.

TCP Server Output NoRead Enable

If it is enabled, and the device will output the content you set in **TCP Server Output NoRead Text** when no code is recognized.

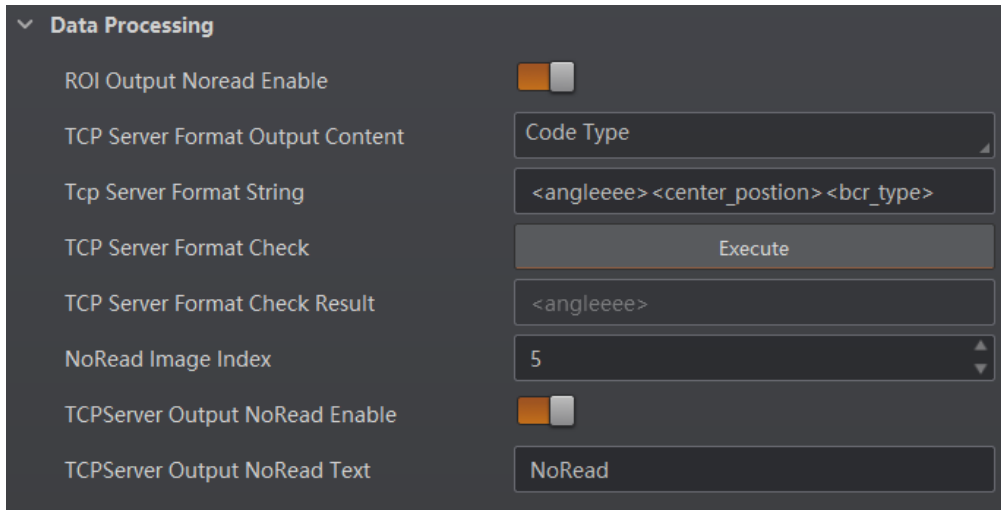

Figure 8-44 Result Output via TCP Server

Result Output via Serial

The device supports using the serial communication protocol to send and receive data, and you can select it to output information. The configurable parameters below are related to the trigger mode, and here we take the external trigger mode as an example.

Note

The configurable parameters may differ if the internal trigger mode is enabled.

ROI Output NoRead Enable

If it is enabled, codes will be outputted in turn according to the **ROI Selector** of the algorithm ROI they belong.

Serial Format Output Content

It selects what contents you want to output, including code content, code type, angle, trigger start time, code score, etc. You can select multiple contents as desired, and the selected contents will be displayed in **Serial Format String**. You are also allowed to directly enter contents in **Serial Format String**.

Serial Format Check

You should click **Execute** in **Serial Format Check** to check if you entered is right in format, and the check result will be displayed in **Serial Format Check Result**.

NoRead Image Index

It sets the specific image that is outputted when no barcode information is read. For example, if you set this parameter as 5, and the 5th image will be output.

Serial Output NoRead Enable

If it is enabled, and the device will output the content you set in **Serial Output NoRead Text** when no code is recognized.

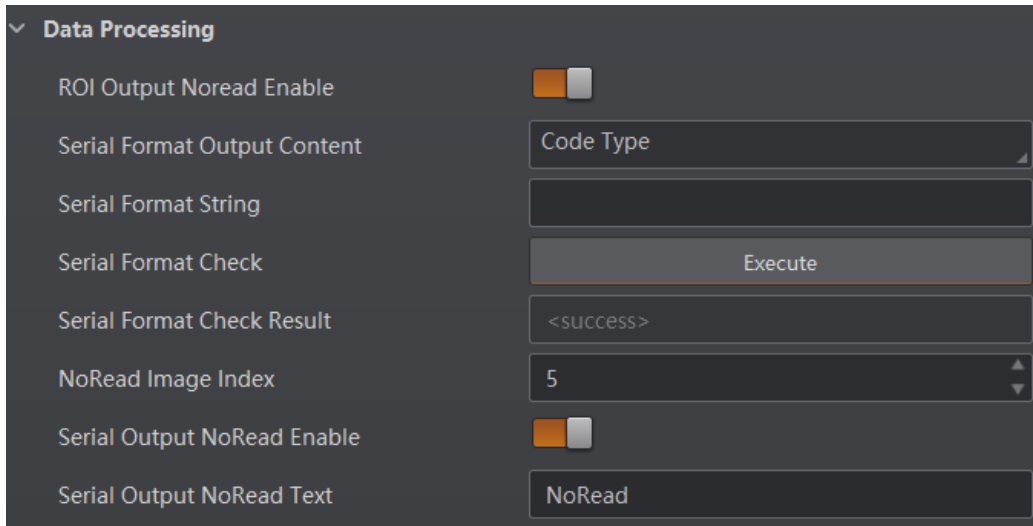

Figure 8-45 Result Output via Serial

Result Output via HTTP

When the communication protocol is **HTTP**, camera mode is **Normal** and trigger mode is **On**, you just need to set **NoRead Image Index** in the **Data Processing**.

Note

When the communication protocol is **HTTP**, camera mode is **Normal** and trigger mode is **Off**, you do not need to set any parameter.

NoRead Image Index

It sets the specific image that is outputted when no barcode information is read. For example, if you set this parameter as 5, and the 5th image will be output.

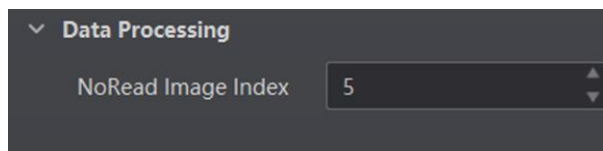

Figure 8-46 Result Output via Smart HTTP

Result Output via FTP

The device also supports using the FTP communication protocol to send and receive data, and you can select it to output information. The configurable parameters below are related to the trigger mode, and here we take the external trigger mode as an example.

Note

The configurable parameters may differ if the internal trigger mode is enabled.

NoRead Image Index

It sets the specific image that is outputted when no barcode information is read. For example, if you set this parameter as 5, and the 5th image will be output.

Output Retrans Enable

If this parameter is enabled, the data is allowed to retransmit to FTP server, and you should set specific value in **Output Retrans Number**.

Note

If data retransmission is still failed after the times allowed for data retransmission is reached, the retransmission will be discarded.

FTP Transmission Conditions

It sets the condition to upload the data outputted by the device to FTP server. **All** refers to upload the data always. **Read Barcode** refers to upload the data only when the barcode is read by the device. **No Read Barcode** refers to ppload the data only when no barcode is read by the device.

FTP Transmission Result Contain

It selects contents to upload to the FTP server. **Just Result** refers to only upload the content of the barcode. **Just Picture** refers to only upload the barcode picture. **Result and Picture** refers to upload both the content of the barcode and the picture.

FTP Image Format

It sets the format of the picture uploaded to FTP server.

Note

The device currently support JPG format only.

FTP File Default Name

It refers to the default name of the file uploaded to FTP server. You can set it according to actual condition.

FTP File Separator

It refers to the separator that separates file name. You can set it according to actual condition.

FTP File Name Contain Package Number Enable

If this parameter is enabled, the name of the file uploaded to FTP server will contain the package ID.

FTP File Name Contain Barcode Number Enable

If this parameter is enabled, the name of the file uploaded to FTP server will contain the number of the barcode.

FTP File Name Contain Barcode Info. Enable

If this parameter is enabled, the name of the file uploaded to FTP server will contain the name of the barcode.

FTP File Name Contain FTP Time Stamp Type

It selects a format type from the drop-down list for the time stamp contained in the file name. Take YYYYMMDD_HHMMSSFFF as an example, (from the left to the right) YYYY represents year, MM represents month, DD represents date, HH represents hour, MM represents minute, SS represents second, and FFF represents millisecond.

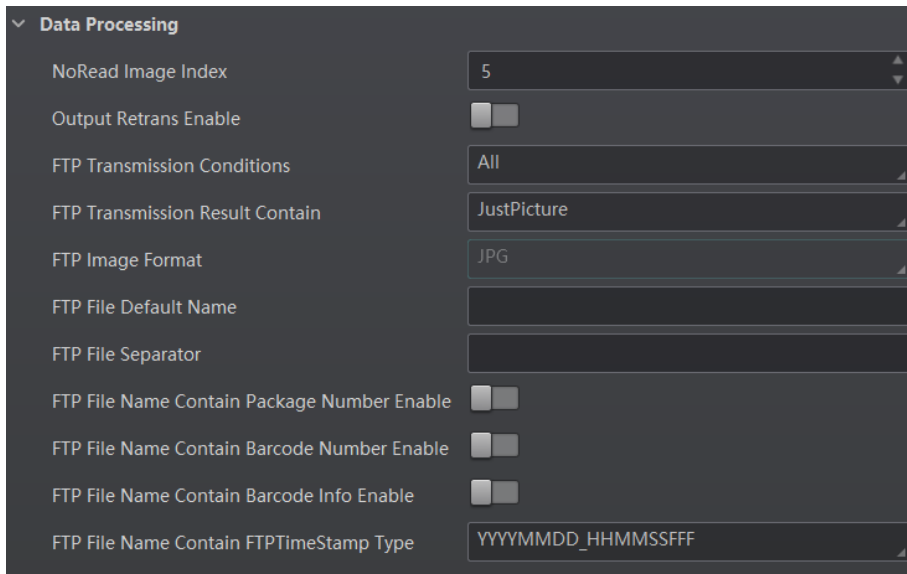

Figure 8-47 Result Output via FTP

Result Output via Profinet

The device supports using the Profinet communication protocol to send and receive data, and you can select it to output information. The configurable parameters below are related to the trigger mode, and here we take the external trigger mode as an example.

 **Note**

The configurable parameters may differ if the internal trigger mode is enabled.

ROI Output NoRead Enable

If it is enabled, codes will be outputted in turn according to the **ROI Selector** of the algorithm ROI they belong.

Profinet Format Output Content

It selects what contents you want to output, including code content, code type, angle, trigger start time, code score, etc. You can select multiple contents as desired, and the selected contents will be displayed in **Profinet Format String**. You are also allowed to directly enter contents in

Profinet Format String.

Profinet Format Check

You should click **Execute** in **Profinet Format Check** to check if you entered is right in format, and the check result will be displayed in **Profinet Format Check Result**.

NoRead Image Index

It sets the specific image that is outputted when no barcode information is read. For example, if you set this parameter as 5, and the 5th image will be output.

Profinet Output NoRead

If it is enabled, and the device will output the content you set in **Profinet Output NoRead Text** when no code is recognized.

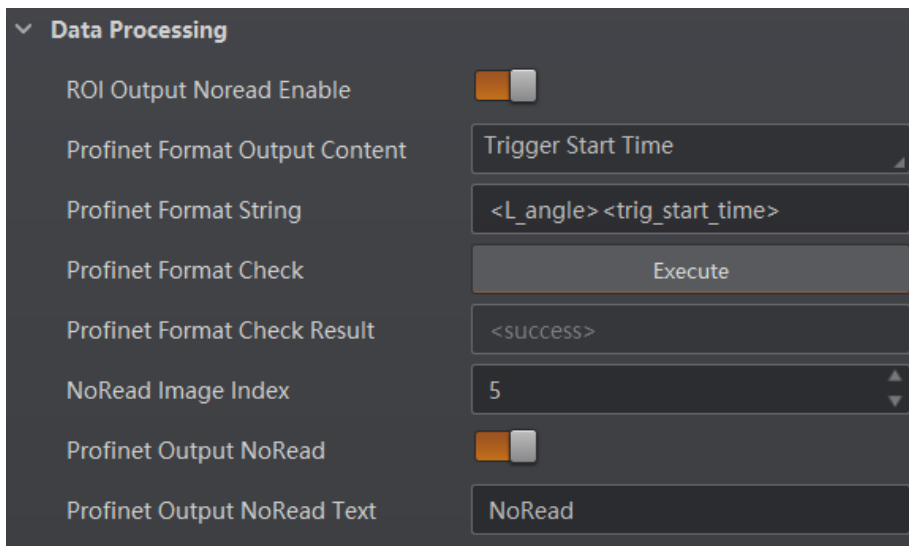

Figure 8-48 Result Output via Profinet

Result Output via Melsec

The device supports using the Melsec communication protocol to send and receive data, and you can select it to output information. The configurable parameters below are related to the trigger mode, and here we take the external trigger mode as an example.

 **Note**

The configurable parameters may differ if the internal trigger mode is enabled.

ROI Output NoRead Enable

If it is enabled, codes will be outputted in turn according to the **ROI Selector** of the algorithm ROI they belong.

Melsec Format Output Content

It selects what contents you want to output, including code content, code type, angle, trigger start time, code score, etc. You can select multiple contents as desired, and the selected contents will be displayed in **Melsec Format String**. You are also allowed to directly enter contents in **Melsec Format String**.

Melsec Format Check

You should click **Execute** in **Melsec Format Check** to check if you entered is right in format, and the check result will be displayed in **Melsec Format Check Result**.

NoRead Image Index

It sets the specific image that is outputted when no barcode information is read. For example, if you set this parameter as 5, and the 5th image will be output.

Melsec Output NoRead

If it is enabled, and the device will output the content you set in **Melsec NoRead Text** when no code is recognized.

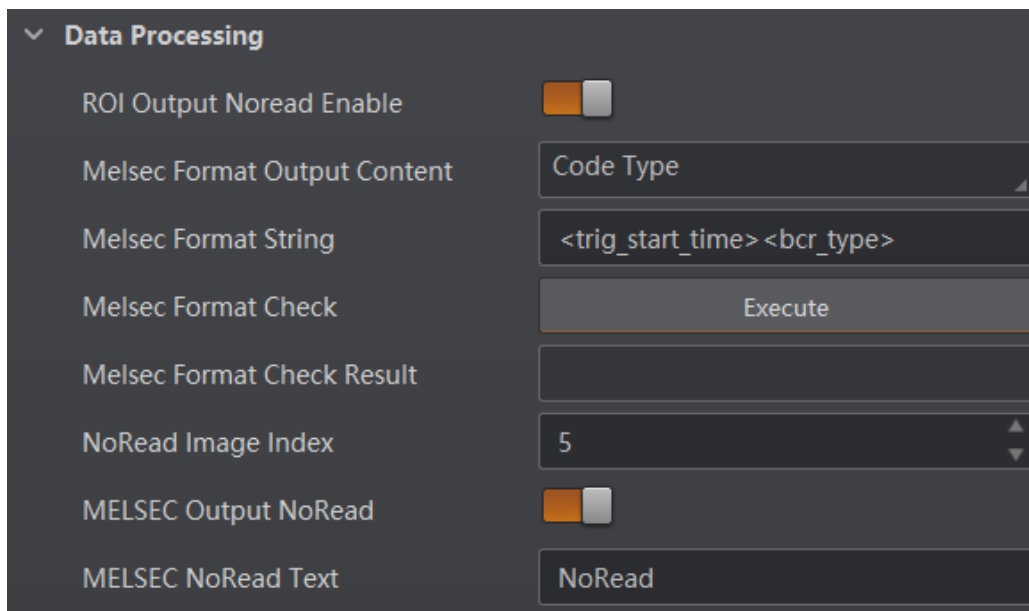

Figure 8-49 Result Output via Melsec

Result Output via Ethernet/IP

The device supports using the Ethernet/IP communication protocol to send and receive data, and you can select it to output information. The configurable parameters below are related to the trigger mode, and here we take the external trigger mode as an example.

Note

The configurable parameters may differ if the internal trigger mode is enabled.

ROI Output NoRead Enable

If it is enabled, codes will be outputted in turn according to the **ROI Selector** of the algorithm ROI they belong.

Ethernet/IP Format Output Content

It selects what contents you want to output, including code content, code type, angle, trigger start time, code score, etc. You can select multiple contents as desired, and the selected contents will be displayed in **Ethernet/IP Format String**. You are also allowed to directly enter contents in **Ethernet/IP Format String**.

Ethernet/IP Format Check

You should click **Execute** in **Ethernet/IP Format Check** to check if you entered is right in format, and the check result will be displayed in **Ethernet/IP Format Check Result**.

NoRead Image Index

It sets the specific image that is outputted when no barcode information is read. For example, if you set this parameter as 5, and the 5th image will be output.

Ethernet/IP Output NoRead

If it is enabled, and the device will output the content you set in **Ethernet/IP Output NoRead Text** when no code is recognized.

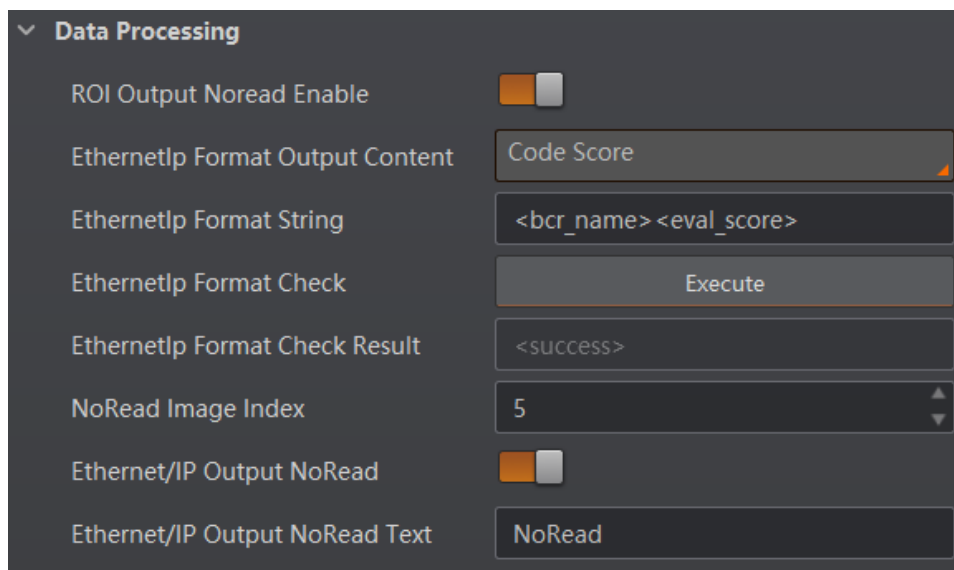

Figure 8-50 Result Output via Ethernet/IP

Result Output via ModBus

The device supports using the ModBus communication protocol to send and receive data, and you can select it to output information. The configurable parameters below are related to the trigger mode, and here we take the external trigger mode as an example.

 **Note**

The configurable parameters may differ if the internal trigger mode is enabled.

ROI Output NoRead Enable

If it is enabled, codes will be outputted in turn according to the **ROI Selector** of the algorithm ROI they belong.

ModBus Format Output Content

It selects what contents you want to output, including code content, code type, angle, trigger start time, code score, etc. You can select multiple contents as desired, and the selected contents will be displayed in **ModBus Format String**. You are also allowed to directly enter contents in **ModBus Format String**.

ModBus Format Check

You should click **Execute** in **ModBus Format Check** to check if you entered is right in format, and the check result will be displayed in **ModBus Format Check Result**.

NoRead Image Index

It sets the specific image that is outputted when no barcode information is read. For example, if you set this parameter as 5, and the 5th image will be output.

ModBus Output NoRead

If it is enabled, and the device will output the content you set in **ModBus Output NoRead Text** when no code is recognized.

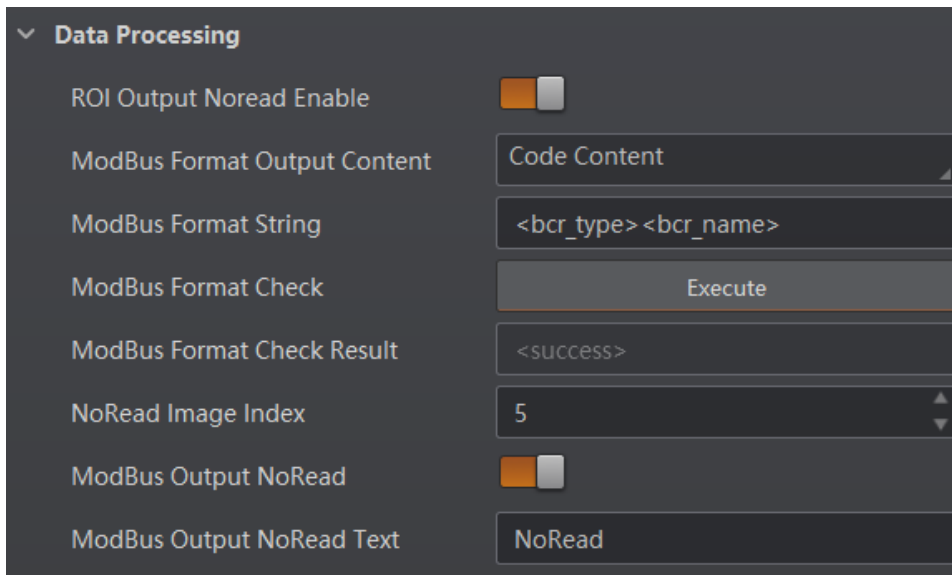

The screenshot shows a configuration window titled "Data Processing" with the following settings:

Parameter	Value
ROI Output Noread Enable	<input checked="" type="checkbox"/>
ModBus Format Output Content	Code Content
ModBus Format String	<bcr_type> <bcr_name>
ModBus Format Check	Execute
ModBus Format Check Result	<success>
NoRead Image Index	5
ModBus Output NoRead	<input checked="" type="checkbox"/>
ModBus Output NoRead Text	NoRead

Figure 8-51 Result Output via ModBus

8.6 Communication Settings

The communication protocol is used to transmit and output code reading result and image. The communication protocol is related to the device modes. With various device modes, the device supports different communication protocols and corresponding parameters.

When the camera mode is **Test** or **Raw**, the device only supports **Smart SDK** protocol and no parameter settings are required. While in **Normal** mode, the device supports **Smart SDK**, **TCP Server**, **TCP Client**, **Serial**, **FTP**, **HTTP**, **Profinet**, **Melsec**, **Ethernet/IP**, and **ModBus** communication protocols, and you need to set corresponding parameters.

8.6.1 Smart SDK

If select **Smart SDK** as the **Communication Protocols**, you can enable **SmartSdk Protocol** to let the device output data via **Smart SDK**.

Encode JPG Flag

If enabled, the device will compress the image data.

Quantity of Jpg

You can enter a number (range: 50 to 99) to determine the compression quality

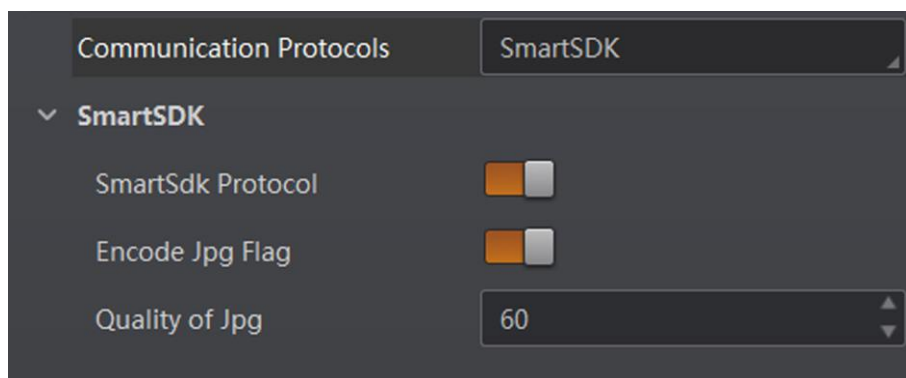

Figure 8-52 Smart SDK

8.6.2 TCP Client

The TCP includes **TCP Server** and **TCP Client**. If select **TCP Client** as the **Communication Protocols**, you need to set following parameters.

Output Result Buffer

If enabled, when the TCP server is abnormal, the device will cache the images. When the server returns to normal, the device will send the cached images to the server. After this parameter being enabled, you can set **Output Result Buffer Number** to determine the number of the images that the device will cache.

You can also enable **TCP Protocol**, enter **TCP Dst Addr** and **TCP Dst Port**.

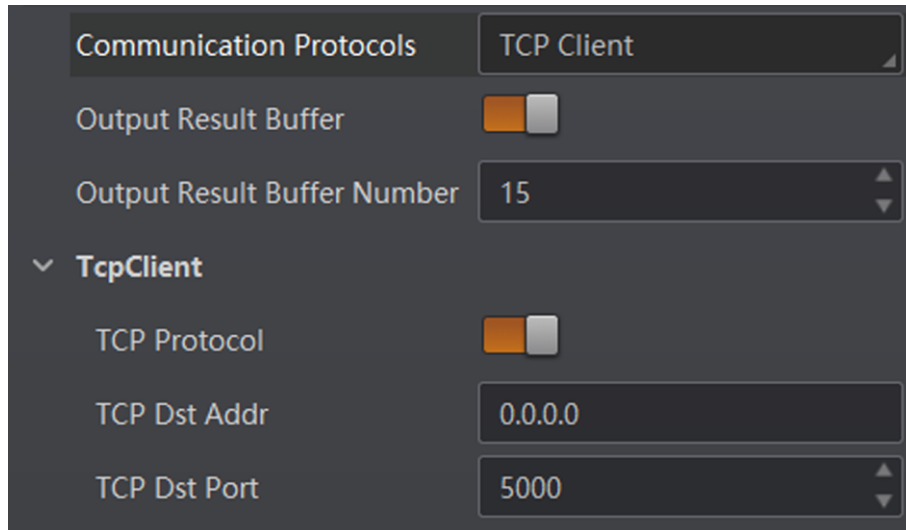

Figure 8-53 TCP Client

8.6.3 TCP Server

The TCP includes **TCP Server** and **TCP Client**. If select **TCP Server** as the **Communication Protocols**, you can enable **Tcp Server Enable**, and enter **Tcp Server Port**.

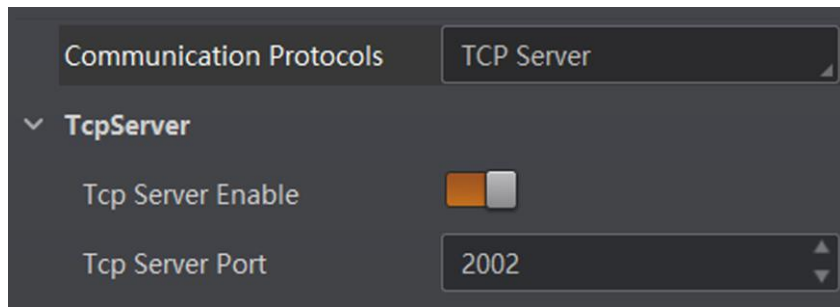

Figure 8-54 TCP Server

8.6.4 Serial

If select **Serial** as the **Communication Protocols**, you can enable **Serial Protocol**, enter **Serial Baud Rate**, **Serial Data Bits**, **Serial Parity**, and **Serial Stop Bits**.

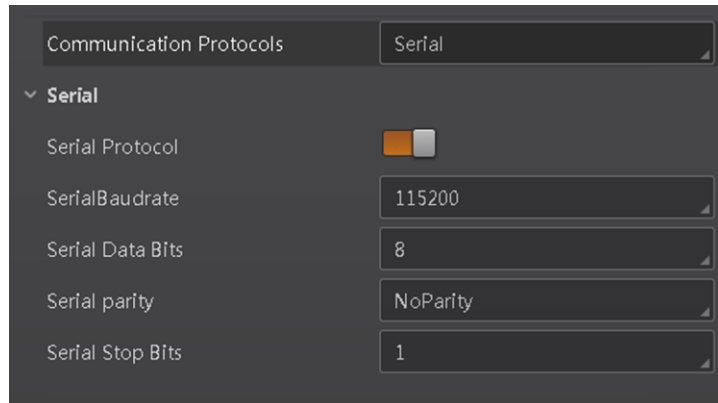

Figure 8-55 Serial

8.6.5 FTP

If select **FTP** as the **Communication Protocols**, you need to set following parameters.

Output Result Buffer

If enabled, when the FTP server is abnormal, the device will cache the images. When the FTP server returns to normal, the device will send the cached images to the server. After this parameter being enabled, you can set **Output Result Buffer Number** to determine the number of the images that the device will cache.

You can also you can enable **FTP Protocol**, enter **FTP Host Addr**,**FTP Host Port**, **FTP User Name**, and **FTP User PWD**.

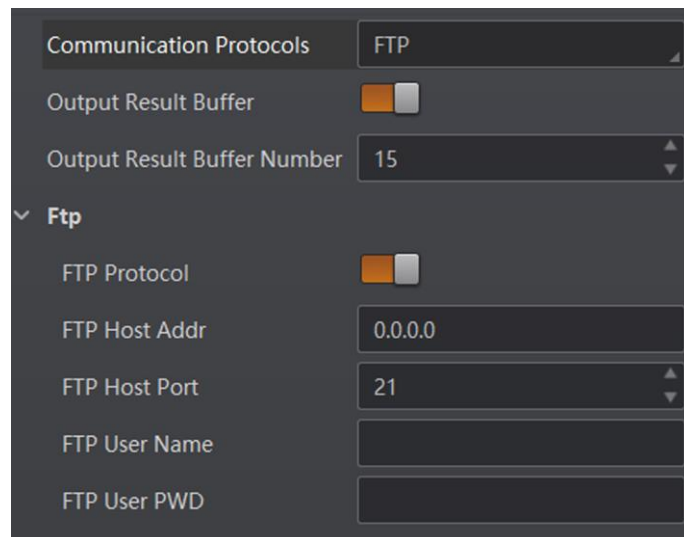

Figure 8-56 FTP

8.6.6 HTTP

If select **HTTP** as the **Communication Protocols**, you can enable **HTTP Server**, enter **HTTP Sever Port** and **WebRefresh Cycle**.

HTTP Server

If enabled, the device will output data via HTTP server.

HTTP Server Port

Enter the port No. of the HTTP server.

WebRefresh Cycle

Set the frequency to refresh the Web.

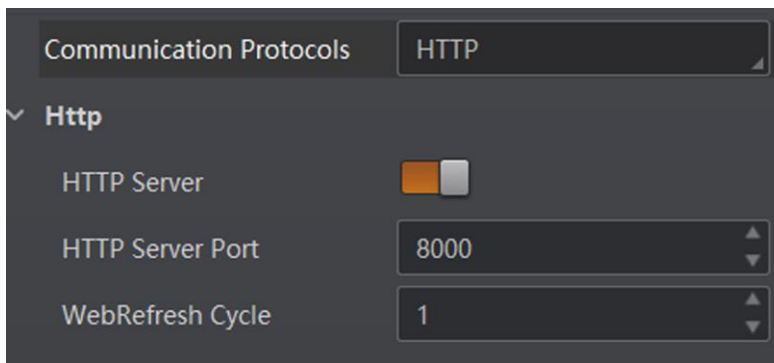

Figure 8-57 HTTP

8.6.7 Profinet

If select **Profinet** as the **Communication Protocols**, you can enable **Profinet Enable** and set **Profinet Device Name** according to actual demands.

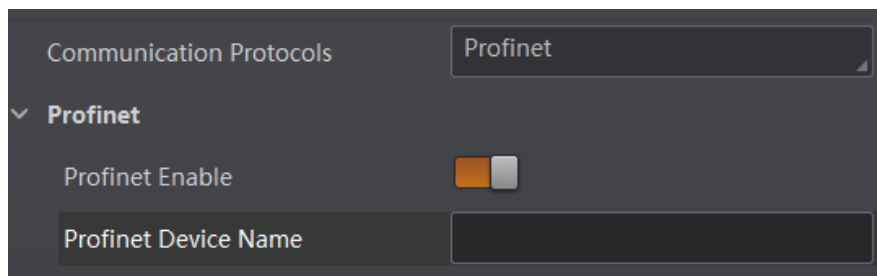

Figure 8-58 Profinet

8.6.8 Melsec

If select **MELSEC** as the **Communication Protocols**, you can enable **MELSEC Protocol Enable** and set related parameters according to actual demands.

MELSEC Destination Address

It sets the IP address of the target PLC.

MELSEC Destination Port

It sets the port number of the target PLC.

MELSEC Data Base Address

It sets the first address of the data area.

MELSEC State Base Address

It sets the first address of the status area.

MELSEC Network Number

It sets the network No.

MELSEC PLC Number

It sets the PLC No.

MELSEC Module I/O Number

It sets the target module's I/O number.

MELSEC Module Station Number

It displays the module station number.

MELSEC Timeout

It sets the waiting time before the returning of PLC's response.

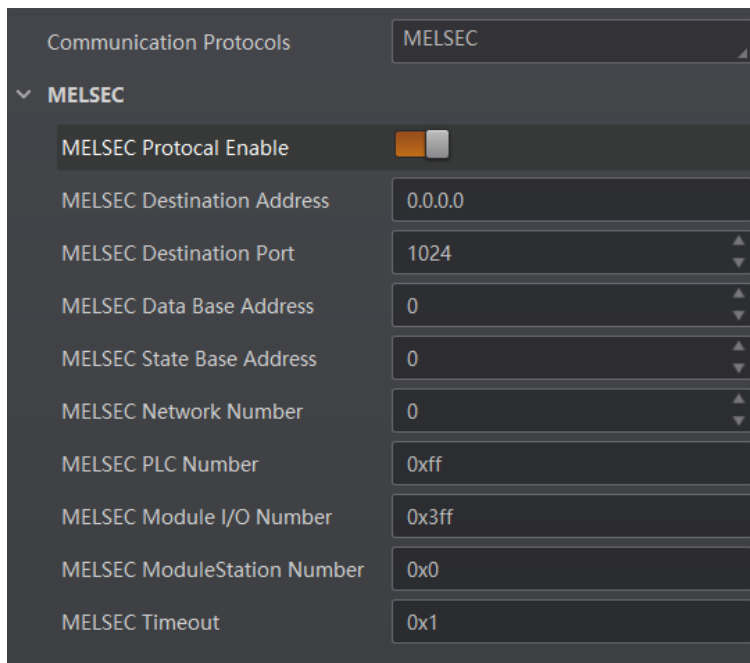

Figure 8-59 Melsec

8.6.9 Ethernet/IP

If select **Ethernet/IP** as the **Communication Protocols**, you can enable **Ethernet/IP Enable**, and the device will output data via Ethernet/IP.

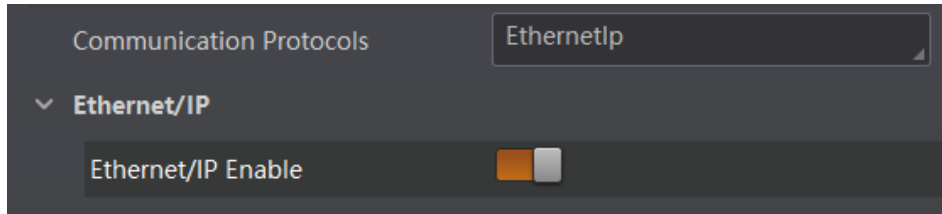

Figure 8-60 Ethernet/IP

8.6.10 ModBus

If select **ModBus** as the **Communication Protocols**, you can enable **ModBus Enable** and set related parameters according to actual demands.

ModBus Control Address Space

It is holding_register by default.

ModBus Control Address Offset

It refers to the address offset, and is 0 by default.

ModBus Control Data Number

It is 2 by default.

ModBus State Address Space

It is input_register by default.

ModBus State Address Offset

It is 0 by default.

ModBus State Data Number

It is 2 by default.

ModBus PLC Input Address Space

It is input_register by default.

ModBus PLC Input Address Offset

It is 2000 by default.

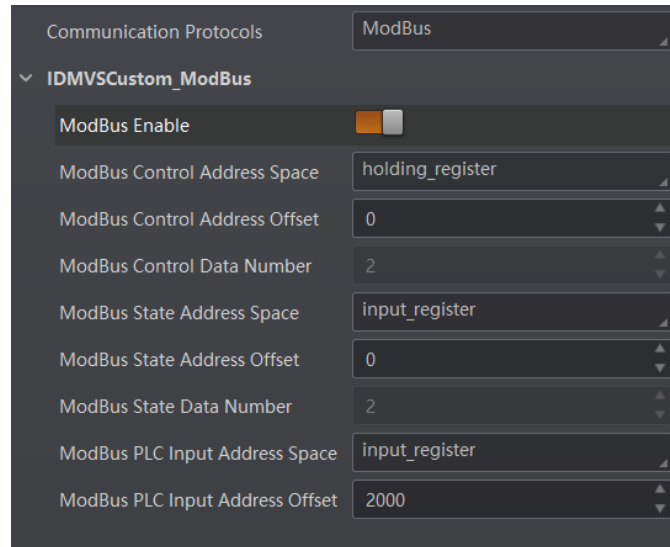

Figure 8-61 ModBus

8.7 User Set Customization

The Configuration Management module allows you to set and manage the user set. A user set is a group of parameter values with all the settings needed to control the device, and you can save, load and switch different user sets.

Save Settings

If you have set the device parameters as desired, you can save them into the user set. Go to **Config Management** → **Save Settings**, and click **UserSet1**, **UserSet2**, or **UserSet3** to save the current device settings.

Load Settings

You can load the user set to restore the device to the saved group of parameter values again if required. Go to **Config Management** → **Load Settings**, and click **Default**, **UserSet1**, **UserSet2**, or **UserSet3** to load settings.

Note

The **Default** refers to restore the device parameter settings to the factory ones.

Start Settings

The selected user set will be automatically loaded after the device being powered on. For example, if you select **Default**, the device parameter settings will be restored to the factory settings.

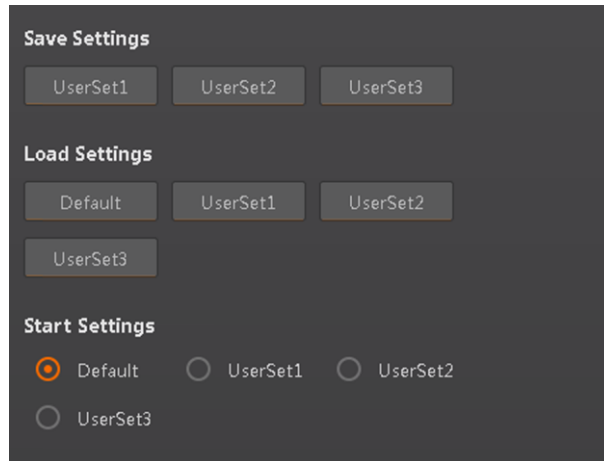

Figure 8-62 User Set Customization

Chapter 9 Camera Operation



The camera operation section introduces some basic camera operations about how to start live view, acquisition and recording, add cross line in the image, split window, view reports, etc.

Note

Connecting the device to the client software is required before camera operation.

9.1 Live View

You can view the real-time image in the live view window.

Click  in live view window to start live view, or click  to stop.

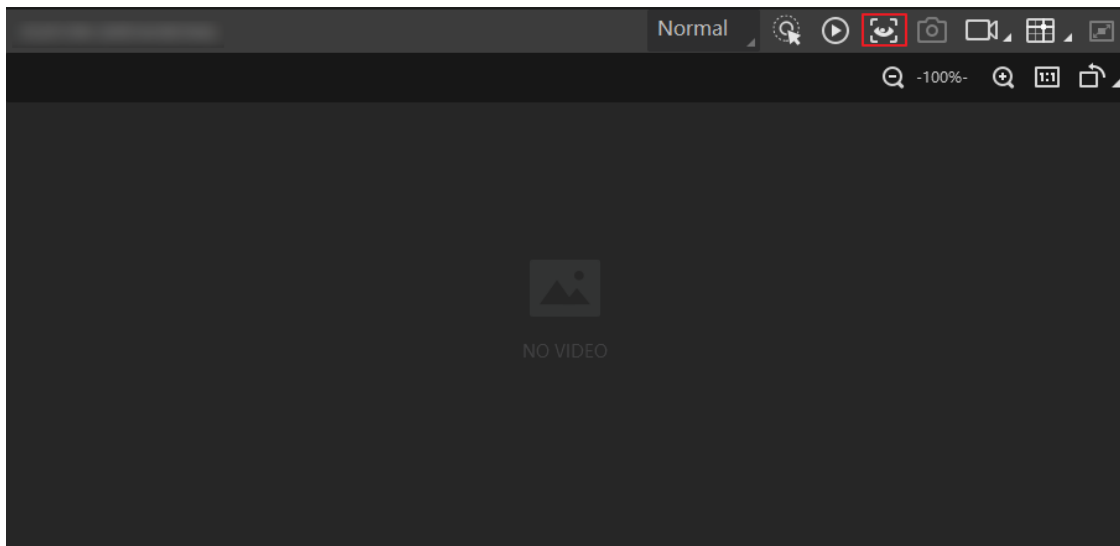



Figure 9-1 Live View

9.2 Enable Acquisition

Enabling acquisition allows the device to acquire the real-time stream.

Click  in live view window to start acquisition, or click  to stop. You can also right click the device on the device list, and click **Stop Acquisition** to stop acquiring streams.

Note

Acquisition is still going on if you only stop live view.

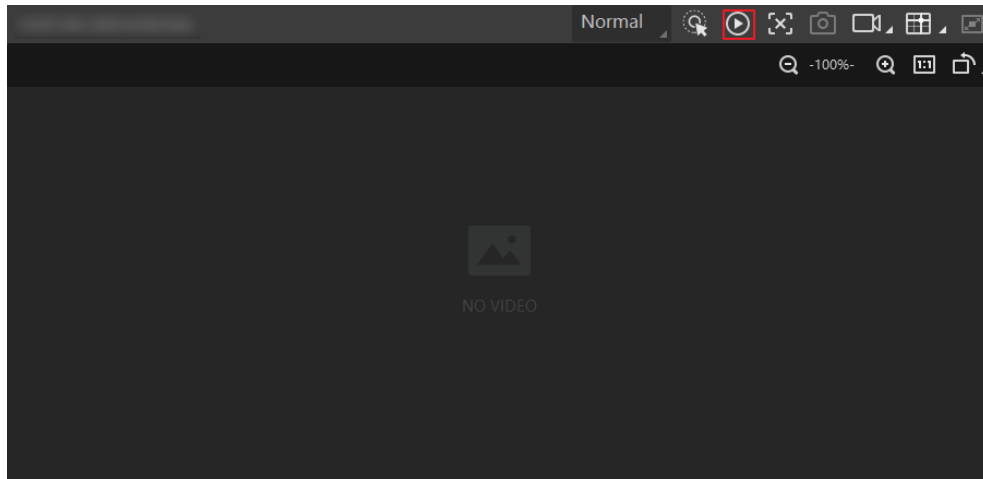

Figure 9-2 Enable Acquisition

9.3 Add Cross Line

During live view, you can add a cross line on the live view image to adjust the position of the object in the view.



Click  in live view window to add cross line, and click  (beside ) to open the editing window to set cross line parameters.







Figure 9-3 Add Cross Line

9.4 Start Recording

During live view, you can record video files and capture images continuously.

Note

Enabling acquisition is required before recording.

Click  in live view window to start recording, and click the icon again to stop. You can also click  (beside ) , and then click  to capture images of the live view continuously.

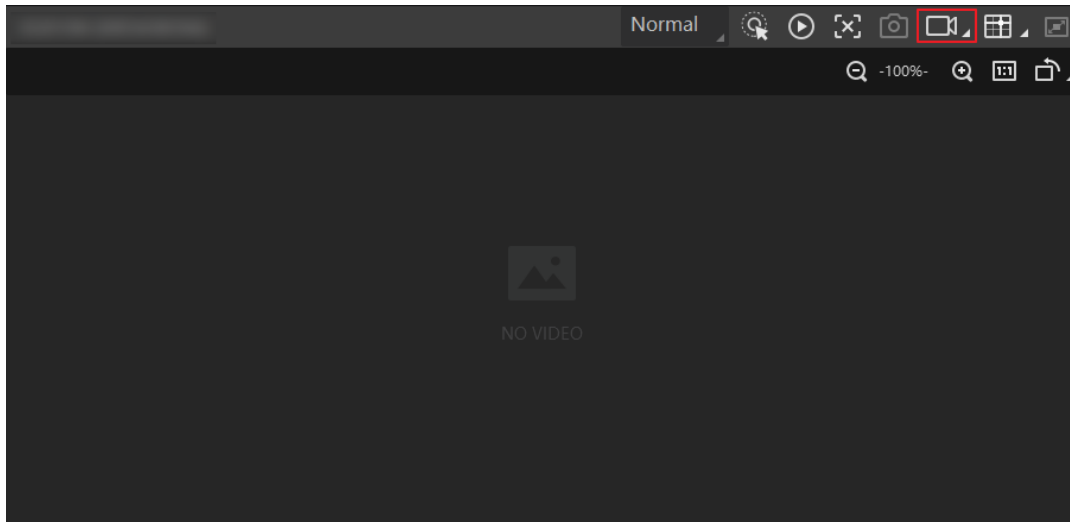



Figure 9-4 Start Recording

9.5 Split Window

The client software supports window division function that allows you to split the window into multiple-window mode to view the live view of multiple devices at the same time.

Click  in control toolbar to select window division mode. You can click **Custom** to customize window division as you desired.

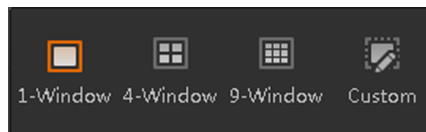



Figure 9-5 Split Window

9.6 View Reports

During acquisition or live view, you can view the reading status of the device.

Click  in control toolbar to open the statistics window to view the detailed information. **Read Code Images** refers to the number of the images on which the barcodes are read by the device. **Unread Code Images** refers to the number of the images on which the barcodes are not read by the device. **Read Rate** refers to the code reading rate.

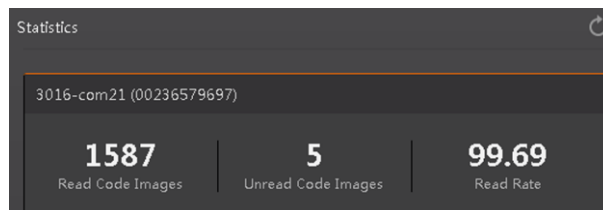



Figure 9-6 View Reports

9.7 View Log

You can view the device logs and export them to the local PC.

Click  in control toolbar to open the device log window, and you can view different types of logs, including device errors, warning, and informational log, etc.

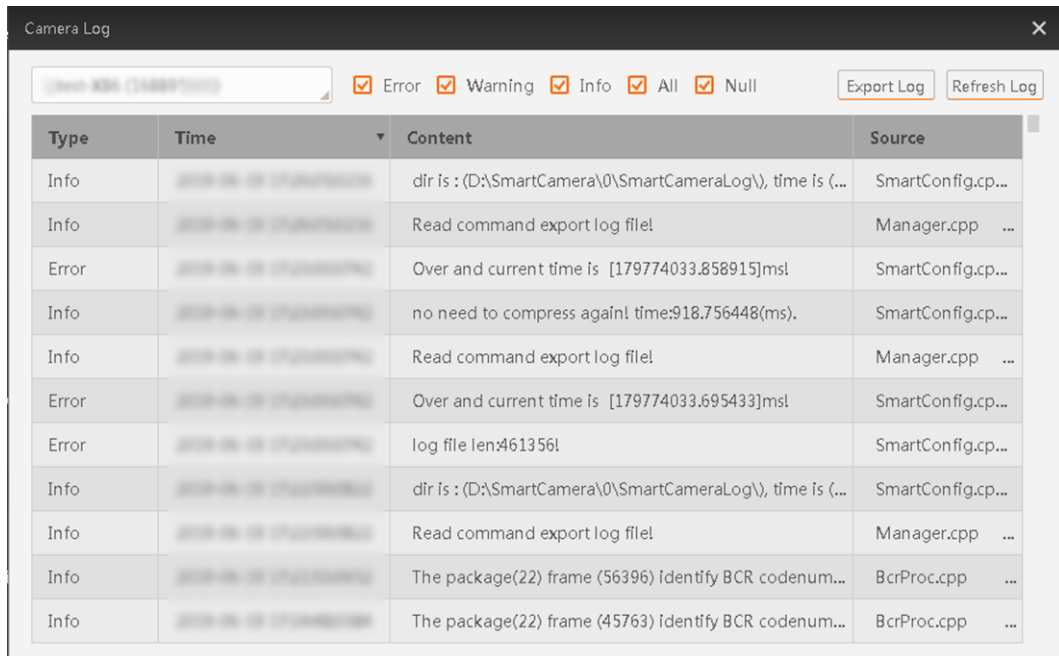

Figure 9-7 View Log

9.8 Enable Camera Auto Work

This function allows the device to automatically enter the operating status after being powered on.

You can go to **Config Management** → **Device Auto Work Enable**, and enable **Device Auto Work Enable**.

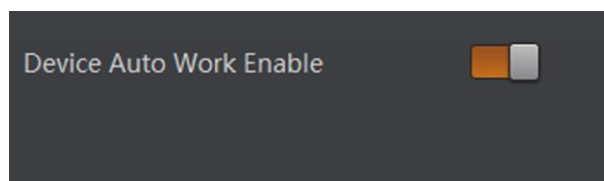

Figure 9-8 Enable Camera Auto Work

Chapter 10 Camera Maintenance

10.1 Update Firmware

The device supports updating firmware via the client software.

Note

- Disconnect the device with client software.
 - Please use the firmware package of the corresponding device model for upgrading.
 - Do not power off the device or disconnect network during upgrading.
 - The device will reboot automatically after updating the firmware.
-

Select the device to be updated in the device list, right click the device, and click **Firmware Update**. Click  to select update file from local PC, and click **Update** to update firmware.

Note

You can also go to **Tool** → **Firmware Updater** to update firmware.

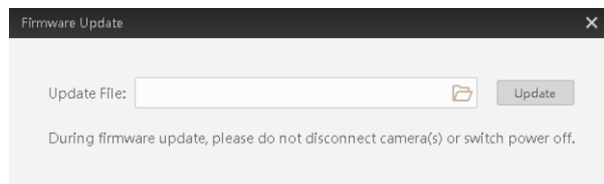

Figure 10-1 Update Firmware

10.2 Reboot Device

You can reboot the device via client software in 2 ways. Go to **Config Management**, and click **Restart Device**. Or, you can select the device to be rebooted in the device list, right click the device, and click **Device Reset**.

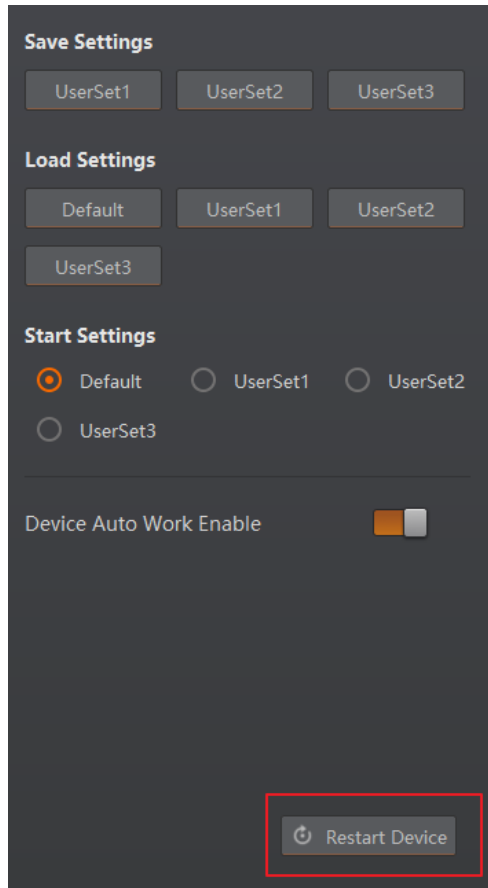

Figure 10-2 Reboot Device

Chapter 11 FAQ (Frequently Asked Question)

11.1 Why the image is very dark?

Problem

All black or too dark during preview.

Reason

- Insufficient brightness of supplement light.
- Too small adjustment value of exposure and gain.

Solution

- Increase the brightness of supplement light appropriately, or change to a brighter one. Increase exposure and gain appropriately.
- Increase exposure and gain appropriately.

11.2 Why the image's frame rate is very low in the live view?

Problem

Image incoherent/Low frame rate/Image tearing when adjusting the view preview.

Reason

Network circuitry speed is not 100 Mbps.

Solution

Check whether network transit speed is 100 Mbps or not.

11.3 Why there is no camera listed after I run the IDMVS client software?

Problem

Run IDMVS client, there is no listed device.

Reason

- The device is powered off.
- Network exception.

Solution

- Check the device power connection (observe whether the top PWR light is solid green or not), to make sure the device is powered up normally.
- Check the network connection (observe whether the top LNK light is flashing green or not), to make sure the device can be connected to the network normally. PC port and the device are in the same network segment.

11.4 Why there is no image in the live view?

Problem

No image in the live view.

Reason

- Enabled trigger mode, but there is no trigger signal.
- Network circuitry speed is not 100 Mbps.

Solution

- Sent the trigger signal to the device/Disable the trigger mode.
- Check whether network circuitry speed is 100 Mbps or not.



See Far, Go Further